

**MEDINA RIVER SEWER OUTFALL:
SEGMENT 4
SAWS JOB #12-2504
Storm Water Pollution Prevention Plan**

**TPDES General Permit
NO. TXR 150000**

**November 2009
(Revised October 2011)**

**MEDINA RIVER SEWER OUTFALL:
SEGMENT 4
SAWS JOB #12-2504
Storm Water Pollution Prevention Plan**

**TPDES General Permit
NO. TXR 150000**

**November 2009
(Revised October 2011)**

Texas Board of Professional Engineers, Firm Registration # 470





LAND DEVELOPMENT ENVIRONMENTAL TRANSPORTATION WATER RESOURCES SURVEYING

October 21, 2011

Mr. Patrick O'Connor
Project Manager
San Antonio Water System (SAWS)
2800 U.S. Highway 281 North
San Antonio, TX 78212

Re: Medina River Sewer Outfall: Segment 4 (SAWS Job #12-2504)
TPDES Storm Water Pollution Prevention Plan

Dear Mr. O'Connor:

Attached please find a copy of the Texas Pollutant Discharge Elimination System (TPDES) Storm Water Pollution Prevention Plan (SWP3) for Medina River Sewer Outfall: Segment 4 (SAWS Job #12-2504) prepared for San Antonio Water System (SAWS). This document is a key element for construction of the referenced project and should be maintained on site at all times during construction. To best protect yourself, we suggest you familiarize yourself with the requirements in the Storm Water Pollution Prevention Plan. Please note, both you and your contractor must complete a Notice of Intent (NOI) form and forward it to the Texas Commission on Environmental Quality (TCEQ) and the San Antonio Water System (SAWS). Both you and your contractor must also complete a Construction Site Notice (CSN) and submit it to SAWS. A Storm Water Quality Site Development Permit Application must also be completed and submitted to Bexar County as instructed in the Plan Implementation Checklist.

In addition, your contractor should pay particular attention to the instructions regarding maintenance and inspections of erosion control items and should maintain the forms included herein.

Should you have any questions regarding this TPDES Storm Water Pollution Prevention Plan, please contact our office. We appreciate the opportunity to serve SAWS on this project.

Sincerely,
Pape-Dawson Engineers, Inc.
Texas Board of Professional Engineers, Firm Registration # 470

Cara C. Tackett, P.E.
Vice President

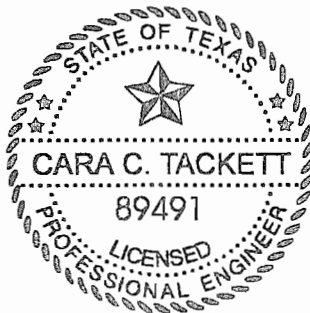

Attachments

P:\68\66\00\Word\Report\TPDES\Segment 4\11017a1.doc

MEDINA RIVER SEWER OUTFALL: SEGMENT 4 (SAWS JOB #12-2504)
Storm Water Pollution Prevention Plan

Table of Contents

PLAN IMPLEMENTATION CHECKLIST (ALL PROJECTS) i

INTRODUCTION 1

I. SITE DESCRIPTION2

II. CONTROLS7

 A. EROSION AND SEDIMENT CONTROLS7

 1. GOALS AND CRITERIA 7

 2. STABILIZATION PRACTICES 9

 3. STRUCTURAL PRACTICES..... 11

 B. POST-CONSTRUCTION STORM WATER MANAGEMENT13

 C. OTHER CONTROLS13

 1. OFF-SITE VEHICLE TRACKING 13

 2. CONSTRUCTION MATERIALS STORAGE..... 14

 3. WASTE DISPOSAL..... 15

 4. HAZARDOUS SUBSTANCES AND HAZARDOUS WASTE 16

 D. STATE, TRIBAL, OR LOCAL CONTROLS18

III. MAINTENANCE19

IV. INSPECTIONS20

V. CONSTRUCTION SUPPORT ACTIVITIES22

VI. NON-STORM WATER DISCHARGES23

VII. SPILL PREVENTION CONTROL AND COUNTERMEASURES (SPCC) PLAN.....24

 A. MATERIALS COVERED24

 B. MATERIAL MANAGEMENT PRACTICES.....24

 C. GOOD HOUSEKEEPING.....25

 D. HAZARDOUS PRODUCTS26

 E. PRODUCT SPECIFIC PRACTICES26

 1. PETROLEUM PRODUCTS..... 26

**MEDINA RIVER SEWER OUTFALL: SEGMENT 4 (SAWS JOB #12-2504)
Storm Water Pollution Prevention Plan**

2. FERTILIZER 27

3. PAINTS, PAINT SOLVENTS, AND CLEANING SOLVENTS 27

4. CONCRETE TRUCKS..... 27

F. SPILL PREVENTION PRACTICES.....28

EXHIBITS

- Exhibit 1 – General Location Map
- Exhibit 2 – Site Plan
- Exhibit 3 – Best Management Practices (BMPs) Details
- Exhibit 4 – Project Milestone Dates
- Exhibit 5 – On-Site Materials List
- Exhibit 6 – Responsible Party Form

ATTACHMENTS

- Notice of Intent (NOI), Construction Site Notice & NOI Tracking Form
- Stormwater Quality Site Development Permit Application (Bexar County)
- Inspection Records
 - Inspection Schedule Form
 - SWP3 Inspection Forms and Corrective Action Items Forms
- Letter Delegating an “Authorized Representative”
- Inspector’s Qualifications
- Plan Modifications
- Notice of Termination
- March 5, 2008 TPDES General Permit TXR150000

MEDINA RIVER SEWER OUTFALL: SEGMENT 4 (SAWS JOB #12-2504)

Storm Water Pollution Prevention Plan

IMPORTANT DEFINITIONS

Primary Operator – the person or persons associated with a large or small construction activity that meets either of the following two criteria:

- (a) the person or persons have operational control over construction plans and specifications, including the ability to make modifications to those plans and specifications; (**Owner/Developer**)
- (b) the person or persons have day-to-day operational control of those activities at a construction site that are necessary to ensure compliance with a Storm Water Pollution Prevention Plan (SWP3) for the site or other permit conditions (e.g., they are authorized to direct workers at a site to carry out activities required by the SWP3 or comply with other permit conditions). (**General Contractor**)

Secondary Operator – The person whose operational control is limited to the employment of other operators or to the ability to approve or disapprove changes to plans and specifications. A secondary operator is also defined as a primary operator and must comply with the permit requirements for primary operators if there are no other operators at the construction site.

PLAN IMPLEMENTATION CHECKLIST (ALL PROJECTS)

1. At least seven (7) days prior to start of construction, the primary operator(s) must submit a Notice of Intent (NOI) – TCEQ Form 20022 (03/05/2008) by Certified Mail-Return Receipt Requested to the following:

Texas Commission on Environmental Quality Storm Water Processing Center (MC-228) P.O. Box 13087 Austin, Texas 78711-3087	TPDES Coordinator San Antonio Water System (MS4) 2800 U.S. Hwy 281 North P.O. Box 2449 San Antonio, Texas 78298
---	---

NOI may be submitted electronically prior to start of construction. To submit a NOI electronically, go to <http://www.tceq.state.tx.us/permitting/steers/steers.html>

Carefully review form and provide all requested information.

2. At least seven (7) days prior to start of construction the primary operator(s) must submit a Construction Site Notice (CSN) to the local Municipal Separate Storm Sewer System (MS4) at the following address:

TPDES Coordinator
San Antonio Water System (MS4)
2800 U.S. Hwy 281 North
P.O. Box 2449
San Antonio, Texas 78298

3. The primary operator(s) must submit a \$325.00 Storm Water Application Fee/Water Quality Fee using Form TCEQ-20134 (03/05/2008) under separate cover to:

<u>If By Regular U.S. Mail</u> Texas Commission on Environmental Quality Financial Administration Division Cashier Office, MC-214 P.O. Box 13088 Austin, Texas 78711-3088	<u>If By Overnight/Express Mail</u> Texas Commission on Environmental Quality Financial Administration Division Cashier's Office MC-214 12100 Park 35 Circle Austin, Texas 78753 (512) 239-0357 or (512) 239-0187
--	---

To pay online go to: <https://www6.tceq.state.tx.us/epay>. The fee is \$225.00 if submitting the NOI electronically.

MEDINA RIVER SEWER OUTFALL: SEGMENT 4 (SAWS JOB #12-2504)

Storm Water Pollution Prevention Plan

4. Incorrect information, omissions of relevant facts, or changes in relevant information provided in the original NOI must be corrected within 14 days after discovery, in writing, in a Notice of Change (NOC) letter or TCEQ Form 20391 (07/13/2007) to the address in 1 above. A transfer of operational control, including transfer of ownership of a company may not be included in an NOC.

Carefully review form and provide all requested information.

5. The primary operator(s), (all parties that submit an NOI) must sign the NOI Tracking Form provided in this SWP3.
6. All Notices of Intent, Notices of Termination, Storm Water Pollution Prevention Plans, reports, certifications, or information either submitted to the Director or to the operator of a large or medium municipal separate storm sewer system, or that this permit requires be maintained by the permittee, shall be signed by a responsible corporate officer, by a general partner or proprietor, by a principal executive public officer, or by a ranking elected public official in accordance with 30 TAC §305.44. A reference copy of this regulation is provided in the "Notice of Intent" section of this SWP3.
7. Post signed copies of all NOIs/NOCs/CSNs in a location where they are readily available for viewing by the general public (e.g., along side of building permit). Copies of all NOIs/NOCs/CSNs shall remain posted until the completion of construction activities. A copy of the SWP3 is to be kept on the construction site.
8. The primary operator(s) must complete the Responsible Party Form (Exhibit 6, Sheet 1 of 2). Additionally, primary operator(s) should use "Responsible Party Form" (Exhibit 6, Sheet 2 of 2) to designate responsibility for pollution prevention measures.
9. The primary operator(s) or general contractor shall designate qualified person(s) to conduct inspections and fill out Inspection Schedule Form and Inspection Forms (copies provided in Storm Water Pollution Prevention Plan). A copy of the inspector's qualifications should be included in this SWP3. The owner/operator may elect to authorize an individual or position having responsibility for the overall operation of the construction activity, or for the owner/operator's environmental matters, to sign inspection reports or other information required by the permit. This authorization must be submitted in writing to the Executive Director of the Texas Commission on Environmental Quality. This authorization cannot include NOI forms, NOT forms, NOC letters, or Construction Site Notices required by this permit.

A form letter for delegating an "Authorized Representative" is included in the "Inspection Record" section of this SWP3.

10. Any field changes or modifications to the SWP3 should be noted on the appropriate exhibit, signed, and dated by the responsible party.
11. Maintain the SWP3 by posting changes, if any, copies of NOIs, NOTs, etc., in plan. File Inspection Forms in SWP3 and retain all records and documents for a minimum period of three years from the date of NOT submittal or terminated coverage.
12. All responsible parties must file a Notice of Termination (NOT) – TCEQ Form 20023 (02/06/2007) (copies in SWP3) within 30 days of when their work has been completed and when the site has been stabilized, or when the operator of storm water discharges changes. Copies should be sent by "Certified Mail - Return Receipt Requested" to the parties identified in 1 above. If a site is turned over to another operator, the existing operator shall notify the new operator in writing of the need to obtain permit coverage.

MEDINA RIVER SEWER OUTFALL: SEGMENT 4 (SAWS JOB #12-2504)

Storm Water Pollution Prevention Plan

PLAN IMPLEMENTATION CHECKLIST (BEXAR COUNTY)

The following are additional items applicable to projects within the limits of Bexar County and outside the jurisdiction of a municipality.

1. At least seven (7) days prior to the start of construction, the primary operator(s) must submit a Storm Water Quality Site Development Permit Application & Fees (\$500) to the following:

Bexar County Infrastructure Services Department
Environmental Services Division
Storm Water Quality
233 N. Pecos – La Trinidad, Suite 420
San Antonio, Texas 78207

Carefully review form and provide all requested information. A copy of this SWP3 must be included.

2. Notify the Bexar County Stormwater Quality Program at least three (3) working days prior to:
 - a. start of construction;
 - b. completion of site clearing;
 - c. completion of final grading;
 - d. when temporary stabilization occurs; and
 - e. completion of final landscaping
3. Terminate the Site Development Permit when the site reaches permanent stabilization. Submit a copy of the TCEQ's Notice of Termination (NOT) to the address listed in Item 1 above.

STORM WATER POLLUTION PREVENTION PLAN

MEDINA RIVER SEWER OUTFALL: SEGMENT 4 (SAWS JOB #12-2504)

Storm Water Pollution Prevention Plan

INTRODUCTION

This Storm Water Pollution Prevention Plan (SWP3) is prepared for the San Antonio Water System (SAWS) and its authorized agents per the guidelines in the TPDES General Permit TXR150000 (TXR150000), dated March 5, 2008, issued pursuant to Chapter 26 of the Texas Water Code and Section 402 of the Clean Water Act, by the Texas Commission on Environmental Quality (TCEQ). This SWP3 is arranged to address Part III, Section F "Contents of SWP3" as it pertains to the proposed construction activities.

This report is prepared for the exclusive use of the San Antonio Water System and its authorized agents. The scope of services performed during the preparation of this report may not be appropriate for other users and such use or reuse of this report is unauthorized, unless the prior written approval of Pape-Dawson Engineers, Inc. (Pape-Dawson) has been obtained.

In the preparation of this report, Pape-Dawson has relied upon certain information supplied by the Client, and upon commonly used sources of data. Pape-Dawson does not warrant the accuracy of the information obtained from those sources and has not independently verified such information.

All conclusions, opinions and recommendations in this report are based upon Pape-Dawson's understanding of site conditions at this time. The development plans presented in this report should not be relied upon to represent conditions at later dates or changes to the development plan.

The contractor shall ensure that the construction site complies with all notification requirements of TXR150000, which are as follows:

- *For sites which disturb five (5) or more acres, or are part of an overall plan of development which is more than five (5) acres, a copy of the NOI prepared by each Operator must be posted near the main entrance of the construction site in a publicly accessible location for*

MEDINA RIVER SEWER OUTFALL: SEGMENT 4 (SAWS JOB #12-2504)
Storm Water Pollution Prevention Plan

viewing by the general public. A Construction Site Notice (CSN) with the name and telephone number of a representative of the Operator who has day to day control over the implementation of the SWP3, a brief description of the construction project, and the location of the SWP3 must also be posted. A signed copy of the NOI form(s) must also be provided, at least seven (7) days prior to commencement of construction activities, to the operator of any Municipal Separate Storm Sewer System (MS4) operator which receives any discharge from the construction site.

I. SITE DESCRIPTION

Project Name: *Medina River Sewer Outfall: Segment 4 (SAWS Job #12-2504)*

Project Street Address: *From approximately 240 feet west of Somerset Road to approximately 100 feet west of Pearsall Road*

Latitude: *N29°17'39.2"*

Longitude: *W98°36'32.4"*

Nature of the Construction Activity: *Construction of 1-66", 1-24" and 1-18" sewer outfall including clearing, grubbing, trenching, tunneling or boring, sewer outfall installation, trench backfilling and project stabilization*

Estimated Construction Start Date: *02/20/12*

Estimated Construction End Date: *08/16/13*

Total Site Area (Acres): *81±*

Approximate Site Area to be Disturbed (Acres): *81±*

Common drainage area serving ten (10) or more acres disturbed at one time: *Yes*

Temporary Sedimentation Basin provided: *No. As this is a linear project over a narrow project area, it is not practical for a sediment basin to be constructed for site disturbance. However, a minimum of 1 foot of topsoil will be removed over the project area and stockpiled for future reclamation purposes. The topsoil removed will effectively create a linear sedimentation basin feature which exceeds 3,600 cf storage per acre disturbed.*

MEDINA RIVER SEWER OUTFALL: SEGMENT 4 (SAWS JOB #12-2504) Storm Water Pollution Prevention Plan

Soil Types: *According to the USDA Natural Resources Conservation Service (NRCS) Web Soil Survey (<http://websoilsurvey.nrcs.usda.gov/app>) for Bexar County the soils on the site are described as follows:*

Gullied land-Sunev complex, 3 to 20 percent slopes (Gu): *This soil type typically occurs along rivers and streams, where terraces and floodplains meet. In a typical soil profile the surface and subsurface layer is clay loam down to around 60 inches. The depth to a restrictive layer is greater than 60 inches. The soil is considered well drained. This soil does not meet hydric criteria.*

Houston Black gravelly clay, 1 to 3 percent slopes (HuB): *This soil type is typically found along long, smooth, convex slopes to shorter undulating slopes along drianageways. In a typical soil profile, the soil layer consists of 36 to 60 inches of gravelly calcareous clay, 10 to 20 percent gravel, overlying clay and marly clay.*

Lewisville silty clay, 0 to 3 percent slopes (LvA, LvB): *This soil type occurs on stream terraces along river valleys. The parent material consists of alluvium of Quaternary age derived from mixed sources. In a typical profile, the soil layer is from 0 to 62 inches of silty clay. Depth to a root restrictive layer is greater than 60 inches. The soil is well drained with a high shrink-swell potential. The minimum depth to a water table is greater than 72 inches. This soil does not meet hydric criteria.*

Tinn clay, 0 to 1 percent slopes, occasionally flooded (Tc): *This soil type occurs along narrow terraces above floodplains. In a typical profile, the soil layer is 0 to 80 inches of moderately alkaline clay. Depth to a root restrictive layer is greater than 60 inches and is well drained. This soil does meet hydric criteria.*

MEDINA RIVER SEWER OUTFALL: SEGMENT 4 (SAWS JOB #12-2504) Storm Water Pollution Prevention Plan

Tinn and Frio soils, 0 to 1 percent slopes, frequently flooded (Tf): These soils occur as narrow, long, and irregularly shaped areas on the flood plains of small streams and the larger field drainage ways. The surface layer is generally clay, ranging from black to grayish-brown in color and is 40 to 70 inches thick. The subsurface layer is a gray to light grayish-brown colored clay, 4 to 20 inches thick. The parent material consists of clayed alluvium of Holocene age derived from mixed sources. The depth to a root restrictive layer is greater than 60 inches. This soil is moderately well drained with very high shrink-swell potential. Frio soils are well drained with moderate shrink-swell potential. Some areas with these soils are subject to a thin deposition of sediments and others to scouring or shifting. Channels in these areas are poorly defined and of small capacity. These soils contain hydric components.

Sunev clay loam, 0 to 3 percent slopes (VcA, VcB): This soil type occurs along and between stream terraces and along deeply entrenched drainage ways. In a typical profile, the soil layer is 0 to 34 inches of moderately alkaline clay loam, 34 to 62 inches of moderately alkaline loam. Depth to a root restrictive layer is greater than 60 inches and is well drained. This soil does not meet hydric criteria.

The site is in Bexar County which receives an average of 30 inches of rainfall annually with the highest amounts of rainfall received in the month(s) of May, June, September and October.

Pre-construction site runoff coefficient: 0.30

Post-construction site runoff coefficient: 0.30

Industrial Activity Discharges: No

Receiving Water: *The site will drain into segment 1903 of the Medina River. This segment is not listed by the TCEQ on the 2008 303(d) list as an impaired water. It is the opinion of Pape-Dawson that construction activities at this site with the practices*

MEDINA RIVER SEWER OUTFALL: SEGMENT 4 (SAWS JOB #12-2504)
Storm Water Pollution Prevention Plan

contained in this SWP3 should not have an adverse impact on these water quality parameters.

Wetlands: Yes. One wetland was identified within the project area. It is within the 100-year floodplain and associated with Medio Creek.

<i>Water Body Type</i>	<i>Acres within Project Area</i>	<i>Anticipated Jurisdictional Status</i>
<i>PEM Wetland</i>	<i>0.003</i>	<i>Jurisdictional</i>

Jurisdictional Waters: From February through June 2009, SWCA conducted a waters of the U.S. determination within the project area. The following are potential waters of the U.S. mapped by SWCA:

<i>Water Body Type</i>	<i>Estimated Acres within Project Area</i>	<i>Coordinates (LONG/LAT)</i>	<i>Anticipated Jurisdictional Status</i>
<i>Stream Channel*</i>	<i>0.03</i>	<i>-98.62128/29.28848</i>	<i>Jurisdictional</i>
<i>Medio Creek</i>	<i>0.08</i>	<i>-98.63710/29.32441</i>	<i>Jurisdictional</i>
<i>Medio Creek</i>	<i>0.08</i>	<i>-98.63154/29.30159</i>	<i>Jurisdictional</i>

**Unnamed ephemeral tributary to Medina River*

Because site construction activities will impact jurisdictional waters of the U.S., a U.S. Army Corps of Engineers Nationwide Permit 12 may be required. The sediment and erosion control practices used on this site will address the requirements of the Nationwide Permit.

Edwards Aquifer Recharge or Contributing Zone: No

EXHIBIT 1 - General Location Map

EXHIBIT 2 - Site Plan illustrating the Storm Water Pollution Prevention Plan including the following, where appropriate:

MEDINA RIVER SEWER OUTFALL: SEGMENT 4 (SAWS JOB #12-2504) Storm Water Pollution Prevention Plan

- Drainage patterns
- Approximate post-grading slopes
- Areas of soil disturbance
- Undisturbed areas
- Locations of major structural and non-structural controls
- Locations of temporary or permanent stabilization practices
- Locations of construction support activities including off-site activities, material, waste, borrow, or equipment storage areas
- Surface waters (including wetlands)
- Storm water discharges to a surface water feature or municipal separate storm sewer system (MS4)
- Vehicle wash areas

EXHIBIT 3 - Typical Details for Best Management Practices (BMPs)

Potential Pollutant Sources:

- Soil erosion due to clearing, grubbing, or excavation for utilities
- Oil, grease, fuel, and hydraulic fluid contamination from construction equipment and vehicle drippings
- Miscellaneous trash and litter from construction workers and material wrappings
- Construction debris
- Concrete truck wash-out water
- Detergents, cleaning solvents
- Paints, paint solvents, other petroleum based products

Sequence of Major Activities:

- Installation of BMPs
- Clearing

MEDINA RIVER SEWER OUTFALL: SEGMENT 4 (SAWS JOB #12-2504)

Storm Water Pollution Prevention Plan

- Grading
- Excavation
- Installation of Utilities (sewer)
- Site Cleanup
- Removal of BMPs

II. CONTROLS

The sequence of major activities of work on this site will be divided into two stages, site preparation and construction. Site preparation consists of clearing, grubbing, grading, or excavation. This work, which is the initiation of all activity on the project, will disturb the largest amount of soil. Therefore, before any of this work can begin, the site contractor will be responsible for the installation and maintenance of control measures as located on Exhibit 2 and illustrated on Exhibit 3. These measures are designed to minimize erosion and minimize eroded soil from leaving the site.

Construction activities include utility installation and site cleanup. Prior to the initiation of construction, all previously installed control measures will be repaired or reestablished for their designed or intended purpose by the construction contractor. The construction contractor will also be responsible for installation of all remaining control measures located on Exhibit 2 and illustrated on Exhibit 3. These controls are intended to prevent eroded soil, trash, and construction debris from leaving the site.

The TXR150000 General Permit requires the permittee to revise or update the SWP3 whenever there is a change in site conditions, new operators, new areas of responsibility, and changes in Best Management Practices. Accordingly the SWP3 is meant to be a dynamic working guide that is to be kept current and amended whenever the design, construction, operation, maintenance, or inspection result indicates that the SWP3 is ineffective in eliminating or significantly minimizing pollutants in storm water

MEDINA RIVER SEWER OUTFALL: SEGMENT 4 (SAWS JOB #12-2504)

Storm Water Pollution Prevention Plan

discharges. All changes to the plan must be shown on Exhibit 2, dated, and signed by the responsible party.

A. EROSION AND SEDIMENT CONTROLS

1. GOALS AND CRITERIA

General goals and criteria for erosion and sediment control are as follows:

- Erosion controls are designed to minimize the amount of erosion which takes place by maximizing the amount of stabilized areas during construction. Sediment controls are designed to retain sediment on site to the maximum extent practicable with consideration for local topography, soil type, and rainfall.
- Control measures must be properly installed and maintained according to the manufacturer's or designer's specifications. If periodic inspections or other information indicates a control has been used incorrectly, or that the control is performing inadequately, the operator must replace or modify the control as soon as practicable after discovery that the control has been used incorrectly, is performing inadequately, or is damaged.
- Sediment must be removed from sediment traps and sedimentation ponds no later than the time that design capacity has been reduced by 50%.
- If sediment escapes the site, accumulations must be removed at a frequency to minimize further negative effects, and whenever feasible, prior to the next rain event.
- Controls must be implemented to limit, to the extent practicable, off-site transport of litter, construction debris, and construction materials.
- Off-site material storage areas such as construction staging areas, soil stockpiles, and borrow areas used solely by the project are considered

MEDINA RIVER SEWER OUTFALL: SEGMENT 4 (SAWS JOB #12-2504) Storm Water Pollution Prevention Plan

part of the project for SWP3 purposes. Contractors will be responsible for establishing appropriate controls for these storage areas, for revising this plan to include those off-site storage areas, and to ensure that these areas are properly covered under the TXR150000.

2. STABILIZATION PRACTICES

Stabilization practices may include but are not limited to: land clearing activities shall be done only in areas where earthwork will be performed and shall progress as earthwork is needed; frequent watering or use of biodegradable soil binders in excavation and fill areas as needed to minimize wind erosion during construction; establishment of temporary vegetation, establishment of permanent vegetation, mulching, geotextiles, sod stabilization, erosion control blankets, Turf Reinforcement Mats (TRM), Bonded Fiber Matrix (BFM), vegetative buffer strips, protection of existing trees and vegetation, and other similar measures. Interim on-site stabilization measures, which are continuous (on-going), will include the following:

- Existing vegetation at the downgradient portion of the site shall be preserved. Ground cover shall not be disturbed until it is necessary to proceed with fieldwork.
- Soil disturbances shall be minimized by exposing only the smallest practical area of land required for the clearing and grading activity and for the construction activity, for the shortest practical period of time.
- Maximum practical use will be made of natural vegetation including grass, weeds, trees, shrubs, etc. by leaving these materials in place until construction necessitates clearing the minimum practical area for continuance of construction.

MEDINA RIVER SEWER OUTFALL: SEGMENT 4 (SAWS JOB #12-2504) Storm Water Pollution Prevention Plan

- Trenching and associated backfilling for utilities and foundations shall be coordinated to minimize to the extent practical the time the area is disturbed.
- Storm water perimeter control devices shall be installed at least 10 feet from stockpile materials. Topsoil stockpiles should be seeded or covered by erosion control blankets, if they are not to be used within fourteen (14) days (TXR150000 Part III (F)(2)(b)(iii)(A)).
- Throughout the project, as necessary, water or environmentally sustainable soil binders shall be applied for dust control.

Permanent on-site stabilization measures, which will be scheduled as detailed below, will include the following:

- As soon as practical, all disturbed soil will be stabilized per applicable project specifications.
- Stabilization measures in this instance shall comply with temporary stabilization as defined in TXR150000 or as defined otherwise in landscape plans where applicable.

Stabilization measures will be initiated as soon as practicable in portions of the site where construction activities have temporarily or permanently ceased, and except as provided below, will be initiated no more than fourteen (14) days after the construction activity in that portion of the site has temporarily or permanently ceased.

- Where construction activity on a portion of the site is temporarily ceased, and earth disturbing activities will be resumed within twenty-one (21) days, temporary stabilization measures do not have to be initiated on that portion of site.

MEDINA RIVER SEWER OUTFALL: SEGMENT 4 (SAWS JOB #12-2504)

Storm Water Pollution Prevention Plan

- In arid areas (areas with an average rainfall of 0 to 10 inches), semiarid areas (areas with an average annual rainfall of 10 to 20 inches), and areas experiencing droughts where the initiation of stabilization measures by the 14th day after construction activity has temporarily or permanently ceased is precluded by seasonably arid conditions, stabilization measures must be initiated as soon as practicable.
- Final stabilization must be achieved prior to termination of permit coverage.
- Final stabilization as defined in TXR150000 (a uniform perennial vegetative cover with a density of at least 70% of the native background vegetative cover for the area) must be achieved prior to termination of permit coverage.
- A final walk-through of the completed construction site shall be performed to ensure final stabilization is established.

Records of project milestone dates are required to be maintained and shall be recorded on Exhibit 4. Project milestones include the following:

- Dates when installation of BMPs begin;
- Dates when site preparation activities begin and end;
- Dates when construction activities begin and end;
- Dates when either site preparation or construction activities temporarily or permanently cease on all or a portion of the project; and
- Dates when stabilization measures are initiated and when stabilization is complete.

MEDINA RIVER SEWER OUTFALL: SEGMENT 4 (SAWS JOB #12-2504)

Storm Water Pollution Prevention Plan

3. STRUCTURAL PRACTICES

On-site structural practices, which are continuous (on-going) until the site is permanently stabilized, may include the following:

- Erection of silt fences, rock berms, straw wattles and tri-dikes as located on Exhibit 2 and illustrated on Exhibit 3;
- Installation of stabilized construction entrances and exits as required and a construction staging area as located on Exhibit 2 and illustrated on Exhibit 3;
- Placement of gravel filter bags as located on Exhibit 2 and illustrated on Exhibit 3;
- Designation of natural vegetated buffer strip areas as located on Exhibit 2;
- Installation of drain inlet protection as located on Exhibit 2 and illustrated on Exhibit 3; and
- Installation of concrete truck wash-out pit as located on Exhibit 2 and illustrated on Exhibit 3.

Where structural controls are shown on TxDOT right-of-way, the contractor must coordinate location and placement of structural controls with the appropriate TxDOT office.

These storm water pollution control features will slow the velocity of runoff thereby enhancing sedimentation and capture of contaminants that may accumulate in storm water runoff exiting this construction site. There are no structures to divert storm water and no structures to store storm water on this project.

MEDINA RIVER SEWER OUTFALL: SEGMENT 4 (SAWS JOB #12-2504)

Storm Water Pollution Prevention Plan

It is to be understood that modifications to the SWP3 may have to be made in the field to adjust for field conditions and to provide the intended effect. All changes to the plan must be shown on Exhibit 2, dated, and signed by the responsible party, or described and included in the Plan Modifications section of this SWP3.

Best management practices may be installed in stages to coincide with the disturbance of upgradient watershed areas.

Best management practices may be removed in stages once the watershed for that portion controlled by the best management practice(s) has been stabilized in accordance with TPDES requirements. Upon completion of the project and before final payment is issued, Contractor shall remove all sediment and erosion control measures, paying special attention to rock berms in drainage features.

Because of the inherent difficulties in maintaining construction schedules due to weather delays, the conditions noted above and listed elsewhere in this plan are provided in lieu of a time related schedule.

B. POST-CONSTRUCTION STORM WATER MANAGEMENT

Unless indicated or required by the soil stabilization project specifications, this project does not require any TPDES post-construction storm water pollution controls or velocity dissipation devices.

C. OTHER CONTROLS

Additional on-site practices, which are continuous (on-going) until the site is permanently stabilized, will include the following:

MEDINA RIVER SEWER OUTFALL: SEGMENT 4 (SAWS JOB #12-2504)

Storm Water Pollution Prevention Plan

1. OFF-SITE VEHICLE TRACKING

- Vehicular traffic leaving the construction site (prior to improved streets) will exit through a stabilized construction exit as located on Exhibit 2 and illustrated on Exhibit 3. When soils have collected on the stabilized vehicular exit to an extent which reduces its intended effectiveness, the surface will be cleaned and reestablished for its designed or intended purpose.
- Mud/dirt inadvertently tracked off site and onto public streets shall be removed immediately by hand or mechanical broom sweeping.
- To the extent practicable, minimize the generation of dust during construction by means including water spray, covering open stockpiles, etc. Spraying of petroleum based or toxic liquids for this purpose is prohibited.

2. CONSTRUCTION MATERIALS STORAGE

- Construction materials shall be stored within a designated storage area as located on Exhibit 2 and illustrated on Exhibit 3. Bulk materials such as sand, topsoil, etc. will be bordered on the downgradient sides with a storm water perimeter control device established at a minimum distance of ten (10) feet from the toe of the stockpile as illustrated on Exhibit 3. A list of materials to be stored on site should be recorded and regularly updated on the "On-Site Materials List" provided in Exhibit 5.
- An area shall be designated as a construction equipment and vehicle storage area as located on Exhibit 2. Construction equipment (except large slow-moving equipment) not removed from the site at night shall be stored in the containment area.

MEDINA RIVER SEWER OUTFALL: SEGMENT 4 (SAWS JOB #12-2504)

Storm Water Pollution Prevention Plan

- Excavation spoils temporarily stored on site, pending off-site disposal in accordance with applicable regulations, shall be bordered on the downgradient side by a storm water perimeter control device established at a minimum distance of ten (10) feet from the toe of the stockpile as illustrated on Exhibit 3 and recorded on the "On-Site Materials List" provided in Exhibit 5.
- The designated construction equipment and vehicle storage area shall have a single entrance and will be bordered on the downgradient sides by a silt fence as illustrated on Exhibit 3.
- Sediment collected behind silt fences will be periodically collected and placed as fill material within the property. Contaminated sediments will be disposed of off site in accordance with applicable regulations.
- The use of on-site temporary construction fuel storage tanks is limited to tank sizes which can only store unregulated quantities of fuel and which have integral spill containment devices with a capacity of at least 110% of tank capacity.
- Intentional release of vehicle or equipment fluid onto the ground is prohibited. In project areas suspected of potential toxic or petroleum products contamination, the soil shall be tested to determine the proper method of disposal.
- Scheduled construction equipment and vehicle maintenance accomplished on site shall be done within the construction equipment and vehicle storage area.

3. WASTE DISPOSAL

- Construction waste materials, domestic garbage, etc. shall be periodically collected in receptacles designated for that purpose and disposed of off site in accordance with applicable regulations.

MEDINA RIVER SEWER OUTFALL: SEGMENT 4 (SAWS JOB #12-2504) Storm Water Pollution Prevention Plan

- All sanitary waste will be collected from the portable toilets by a licensed portable facility provider in complete compliance with local and state regulations.
- A controlled on-site area as located on Exhibit 2 and illustrated on Exhibit 3 shall be designated as a concrete truck wash-out pit for concrete trucks. Truck wash-out pits shall be surrounded by a berm or hay bales to prevent runoff of contaminated water. The contractor will advise his concrete suppliers of the requirements to utilize the wash-out pits for the intended purpose.
- Direct discharge of concrete truck wash-out water to surface waters of the state, including discharge to storm sewers, is prohibited by this general permit.
- Concrete truck wash-out water shall be discharged to areas at the construction site where structural controls have been established to prevent direct discharge to surface waters, or to areas that have a minimal slope that allow infiltration and filtering of wash-out water to prevent direct discharge to surface waters. Structural controls may consist of temporary berms, temporary shallow pits, temporary storage tanks with slow rate release, or other reasonable measures to prevent runoff from the construction site.
- Wash out of concrete trucks during rainfall events shall be minimized, and the operator shall ensure that its BMPs are sufficient to prevent the discharge of concrete truck wash-out as the result of rain. The direct discharge of concrete truck wash-out water to surface water in the state, including discharge to storm sewers, is prohibited at all times.
- The discharge of wash-out water shall not cause or contribute to groundwater contamination.

MEDINA RIVER SEWER OUTFALL: SEGMENT 4 (SAWS JOB #12-2504)

Storm Water Pollution Prevention Plan

- Concrete truck wash-out water and residual concrete may be directed into the open sewer trench as long as groundwater is not present.
- Additional concrete truck wash-out pits may be added as construction conditions require.

4. HAZARDOUS SUBSTANCES AND HAZARDOUS WASTE

- Hazardous waste materials will be disposed of in the manner specified by local, state, and/or federal regulations and by the manufacturer of such products. Site personnel will be instructed in these practices by the job site superintendent, who will also be responsible for seeing that these practices are followed. Each employee who must handle a substance with hazardous properties will be instructed on the use of the product he/she is using, particularly regarding spill control techniques.
- The contractor will implement the Spill Prevention Control and Countermeasures (SPCC) Plan found within this SWP3 and will train all personnel in the proper cleanup and handling of spilled materials. No spilled hazardous materials or hazardous wastes will be allowed to come in contact with storm water discharges. If such contact occurs, the storm water discharge will be contained on site until appropriate measures in compliance with state and federal regulations are taken to dispose of such contaminated storm water. It shall be the responsibility of the job site superintendent to properly train all personnel in the use of the SPCC plan.
- Any spills of hazardous materials which are in quantities in excess of Reportable Quantities as defined by TCEQ regulations shall be immediately reported to the TCEQ National Response Center 1-800-832-8224.
- In order to minimize the potential for a spill of hazardous materials to come into contact with storm water, the following steps will be implemented:

MEDINA RIVER SEWER OUTFALL: SEGMENT 4 (SAWS JOB #12-2504)
Storm Water Pollution Prevention Plan

- a. All materials with hazardous properties (such as pesticides, petroleum products, fertilizers, detergents, construction chemicals, acids, paints, paint solvents, cleaning solvents, additives for soil stabilization, concrete curing compounds and additives, etc.) will be stored in a secure location, under cover, when not in use.
- b. The minimum practical quantity of all such materials will be kept on the job site.
- c. A spill control and containment kit (containing, for example, absorbent material such as kitty litter or sawdust, acid neutralizing powder, brooms, dust pans, mops, rags, gloves, goggles, plastic and metal trash containers, etc.) will be provided at the storage site.
- d. All of the product in a container will be used before the container is disposed of. All such containers will be triple-rinsed with water prior to disposal. The rinse water used in these containers will be disposed of in a manner in compliance with state and federal regulations and will not be allowed to mix with storm water discharges.
- e. All products will be stored in and used from the original container with the original product label.
- f. All products will be used in strict compliance with instructions on the product label.
- g. The disposal of excess or used products will be in strict compliance with instructions on the product label.

D. STATE, TRIBAL, OR LOCAL CONTROLS

The site is not located over the Edwards Aquifer Contributing Zone or Recharge Zone.

The site is not located on Native American Tribal lands.

MEDINA RIVER SEWER OUTFALL: SEGMENT 4 (SAWS JOB #12-2504)

Storm Water Pollution Prevention Plan

Except as noted herein, there are no other known applicable state, tribal, or local storm water pollution prevention control requirements for construction projects at this location.

All activities during construction shall comply with state and local sanitary sewer, septic system, and waste disposal regulations.

Trees, limbs, leaves, brush, and vegetation from clearing operations shall be removed from the site and disposed of off site in accordance with applicable regulations.

Excavation spoils which will not be reused on this construction project shall be disposed of off site at an approved location in accordance with applicable regulations.

III. MAINTENANCE

Structural controls shall be inspected as stipulated in this plan. Structural units shall be maintained to perform the function as intended until all soil disturbing activities have been completed and a uniform (e.g., evenly distributed, without large bare areas) perennial vegetative cover with a density of 70% of the native background vegetative cover for the area has been established in all unpaved areas and areas not covered by permanent structures, or equivalent permanent stabilization measures (such as the use of riprap, gabions, or geotextiles) have been employed.

When a sediment control structure deteriorates to a condition so that its performance is less than intended, the structure shall be repaired or replaced to full function as specified before the next anticipated storm event or as necessary to maintain the continued effectiveness of storm water controls. If maintenance prior to the next anticipated storm

MEDINA RIVER SEWER OUTFALL: SEGMENT 4 (SAWS JOB #12-2504)

Storm Water Pollution Prevention Plan

event is impracticable, the reason shall be documented in the SWP3 and maintenance must be scheduled and accomplished as soon as practicable.

Erosion and sediment controls that have been intentionally disabled, run over, removed, or otherwise rendered ineffective must be replaced or corrected immediately upon discovery. Controls which have been used incorrectly, are performing inadequately, or are damaged must be replaced or modified as soon as possible after discovery of the deficiency.

Particular attention should be paid to the sedimentation areas behind the rock berms and silt fences. When the sediment has accumulated to six inches or more behind a rock berm or silt fence, (from construction debris, tree trimming, trash, municipal type garbage, etc.) it will be removed and the rock berms and silt fences will be restored to their original specifications. Contaminated sediment removed from containment areas (vehicle maintenance, concrete wash-out pits, etc.) shall be either used on site if suitable for fill material or disposed of off site in accordance with appropriate regulations. If sediment escapes the site, the permittee must work with the downgradient property owner to remove the sediment as soon as possible.

Exhibit 6, Sheet 2 of 2 lists the various major components of this pollution prevention plan and identifies the party responsible for its function, maintenance, and inspections.

IV. INSPECTIONS

Designated and qualified person(s) shall inspect Pollution Control Measures every fourteen days and within twenty-four (24) hours after a storm event greater than 0.5 inches of rainfall at the project site. As an alternative, inspections may be scheduled at least once every seven (7) calendar days. The inspection must occur on a specifically defined day, regardless of whether or not there has been a rainfall event since the previous

MEDINA RIVER SEWER OUTFALL: SEGMENT 4 (SAWS JOB #12-2504) Storm Water Pollution Prevention Plan

inspection. The inspections may occur on either schedule provided that the SWP3 reflects the current schedule and that any changes to the schedule are conducted in accordance with the following provisions: the schedule may be changed a maximum of one time each month, the schedule change must be implemented at the beginning of a calendar month, and the reason for the schedule change must be documented in the Inspection Record section of the SWP3. In the event of flooding or other uncontrollable situations which prohibit access to the inspection sites, inspections must be conducted as soon as access is practicable. Where sites have been finally or temporarily stabilized, inspections must be conducted at least once every month.

Linear projects (e.g. utility line installation, pipeline, construction, etc.) may schedule representative inspections. For representative inspections, personnel must inspect controls along the construction site for 0.25 mile above and below each access point where a roadway, undisturbed right-of-way, or other similar feature intersects the construction site and allows access to the site.

An inspection report that summarizes the scope of the inspection, names and qualifications of personnel conducting the inspection, date of the inspection, major observations, and actions taken as a result of the inspection shall be recorded and maintained as part of Storm Water TPDES data for a period of three years after the Notice of Termination (NOT) has been filed. Major observations should include:

- Locations of discharges of sediment or other pollutants from the site;
- Locations of BMPs that need to be maintained;
- Locations of BMPs that failed to operate as designed or proved inadequate; and
- Locations where additional BMPs are needed.

A copy of the Inspection Report Form is provided in the "Inspection Record" section of this SWP3.

MEDINA RIVER SEWER OUTFALL: SEGMENT 4 (SAWS JOB #12-2504)

Storm Water Pollution Prevention Plan

As a minimum, the inspector shall observe:

- significant disturbed areas for evidence of erosion;
- storage areas for evidence of leakage from the exposed stored materials;
- discharge locations for signs of erosion or sediment;
- structural controls (rock berm outlets, silt fences, tri-dikes, straw wattles, etc.) for evidence of failure or excess siltation (over 6 inches deep);
- vehicle exit point for evidence of off-site sediment tracking;
- vehicle storage areas for signs of leaking equipment or spills;
- concrete truck wash-out pit for signs of potential failure; and
- general site cleanliness.

Deficiencies noted during the inspection will be corrected and documented within seven (7) calendar days following the inspection or before the next anticipated storm event if practicable.

When an inspection does not identify any incident of non-compliance, the report must contain a certification signed in accordance with 30 TAC §305.128 stating the site is in compliance with the SWP3 and the TPDES general permit conditions.

Exhibit 6, sheet 2 of 2 lists the various major components of this pollution prevention plan and identifies the party responsible for its function, maintenance, and inspection.

V. CONSTRUCTION SUPPORT ACTIVITIES

Examples of construction support activities include, but are not limited to, concrete batch plants, rock crushers, asphalt batch plants, equipment staging areas, material storage yards, material borrow areas, and excavated material disposal areas. Discharges of storm water runoff from construction support activities may be authorized under this general permit, provided that the following conditions are met:

MEDINA RIVER SEWER OUTFALL: SEGMENT 4 (SAWS JOB #12-2504) Storm Water Pollution Prevention Plan

- a. the activities are located within one (1)-mile from the boundary of the permitted construction site and directly support the construction activity.
- b. a SWP3 is developed according to the provisions of this general permit and includes appropriate controls and measures to reduce erosion and discharge of pollutants in storm water runoff from the construction support activities; and
- c. the construction support activities either do not operate beyond the completion date of the construction activity or are authorized under separate TPDES authorization. Separate TPDES authorization may include the TPDES Multi Sector General Permit, TXR050000 (related to storm water discharges associated with industrial activity), separate authorization under this general permit if applicable, coverage under an alternative general permit if available, or authorization under an individual water quality permit.

VI. NON-STORM WATER DISCHARGES

Storm water discharges from this construction site may be intermittently mixed with the following non-storm water discharges:

- discharges from fire fighting activities (fire fighting activities do not include washing of trucks, runoff water from training activities, test water from fire suppression systems and similar activities);
- uncontaminated fire hydrant flushings (excluding discharges of hyperchlorinated water, unless the water is first dechlorinated and discharges are not expected to adversely affect aquatic life), which include flushings from systems that utilize potable water, surface water, or groundwater that does not contain additional pollutants (uncontaminated fire hydrant flushings do not include systems utilizing reclaimed wastewater as a source water);
- water from the routine external washing of vehicles, external portion of buildings or structures, and pavement;
- discharges where detergents and soaps are not used;

MEDINA RIVER SEWER OUTFALL: SEGMENT 4 (SAWS JOB #12-2504) Storm Water Pollution Prevention Plan

- discharges where spills or leaks of toxic or hazardous materials have not occurred (unless spilled materials have been removed; and if local state, or federal regulations are applicable, the materials are removed according to those regulations);
- discharges where pressure washing is not conducted, and where the purpose is to remove mud, dirt, or dust;
- uncontaminated water used to control dust;
- potable water sources including waterline flushings (excluding discharges of hyperchlorinated water, unless the water is first dechlorinated and discharges are not expected to adversely affect aquatic life);
- uncontaminated air conditioning condensate;
- uncontaminated ground water or spring water, including foundation or footing drains where flows are not contaminated with industrial materials such as solvents;
- lawn watering and similar irrigation drainage; and
- any discharge authorized under a separate NPDES, TPDES, or TCEQ permit may also be combined with storm water discharges from this construction site.

The above non-storm water components would exit the site via the storm water drainage paths and would be subject to the same filtering and sedimentation control provided by the vegetated drainage channels and structural controls used for storm water runoff. Other non-storm water discharges are not anticipated from the construction of this project.

VII. SPILL PREVENTION CONTROL AND COUNTERMEASURES (SPCC) PLAN

A. MATERIALS COVERED

The following materials or substances with known hazardous properties are expected to be present on site during construction:

Concrete

Cleaning solvents

Detergents

Petroleum based products

MEDINA RIVER SEWER OUTFALL: SEGMENT 4 (SAWS JOB #12-2504)
Storm Water Pollution Prevention Plan

Paints	Pesticides
Paint solvents	Acids
Fertilizers	Concrete additives
Soil stabilization additives	

B. MATERIAL MANAGEMENT PRACTICES

The following are the material management practices that will be used to reduce the risk of spills or other accidental exposure of materials and substances to storm water runoff:

- Personnel will be trained in the proper storage, use, and disposal of on-site materials;
- Materials will be stored in areas identified for that purpose and containment will be provided;
- Materials will be secured to prevent unauthorized use or vandalism;
- Material storage will be limited to reasonable quantities; and
- Waste materials will be collected in receptacles designed for the purpose and disposed of off site in accordance with applicable regulations.

C. GOOD HOUSEKEEPING

The following good housekeeping practices will be followed on site during the construction project.

- An effort will be made to store only enough product required to do the job;
- All materials stored on site will be stored in a neat, orderly manner and, if possible, under the roof or other enclosure;
- Products will be kept in their original containers with the original manufacturer's label in legible condition;
- Substances will not be mixed with one another unless recommended by the manufacturer;

MEDINA RIVER SEWER OUTFALL: SEGMENT 4 (SAWS JOB #12-2504)

Storm Water Pollution Prevention Plan

- Whenever possible, all of a product will be used up before disposing of the container;
- Manufacturer's recommendations for proper use and disposal will be followed; and
- The job site superintendent will be responsible to ensure proper use and disposal of materials.

D. HAZARDOUS PRODUCTS

These practices will be used to reduce the risk associated with hazardous materials.

- Products will be kept in original containers with the original labels in legible condition;
- Original labels and material safety data sheets (MSDS's) will be procured and used for each material;
- If surplus product must be disposed of, manufacturers or local/state/federal recommended methods for proper disposal will be followed;
- A spill control and containment kit (containing, for example, absorbent materials such as kitty litter or sawdust, acid neutralizing powder, brooms, dust pans, mops, rags, gloves, goggles, plastic and metal trash containers, etc.) will be provided at the storage site; and
- All of the product in a container will be used before the container is disposed of. All such containers will be triple-rinsed with water prior to disposal. The rinse water used in these containers will be disposed of in a manner in compliance with state and federal regulations and will not be allowed to mix with storm water discharges.

E. PRODUCT SPECIFIC PRACTICES

The following product-specific practices will be followed on the job site.

MEDINA RIVER SEWER OUTFALL: SEGMENT 4 (SAWS JOB #12-2504) Storm Water Pollution Prevention Plan

1. PETROLEUM PRODUCTS

All on-site vehicles will be monitored for leaks and receive regular preventative maintenance to reduce the chance of leakage. Petroleum products will be stored in tightly sealed containers which are clearly labeled. Any petroleum storage tanks used on site will have a dike or berm containment structure constructed around it to contain any spills which may occur. Any asphalt substances used on site will be applied according to the manufacturer's recommendations.

2. FERTILIZER

Fertilizers will be applied only in the minimum amounts recommended by the manufacturer. Once applied, fertilizer will be worked in the soil to limit exposure to storm water. The contents of any partially used bags of fertilizer will be transferred to a sealable plastic bin to avoid spills.

3. PAINTS, PAINT SOLVENTS, AND CLEANING SOLVENTS

All containers will be tightly sealed and stored when not in use. Excess paint and solvent will not be discharged to the storm sewer system but will be properly disposed of according to manufacturer's instructions or state and federal regulations.

4. CONCRETE TRUCKS

TXR150000 authorizes the land disposal of wash-out water from concrete trucks that are associated with off-site production facilities, as long as the discharge is in compliance with the restrictions of this SWP3. Wash-out water associated with on-site concrete production facilities is not authorized by the TXR150000 General Permit and must be authorized under a separate TCEQ General Permit or individual permit. Direct

MEDINA RIVER SEWER OUTFALL: SEGMENT 4 (SAWS JOB #12-2504)

Storm Water Pollution Prevention Plan

discharge of concrete truck wash-out water to surface waters in the state, including discharge to storm sewers is prohibited by the TXR150000 General Permit. Wash out of concrete trucks during rainfall events shall be minimized and the operator shall ensure that its BMPs are sufficient to prevent the discharge of concrete truck wash-out as the result of rain. The direct discharge of concrete truck wash-out water to surface water in the state, including discharge to storm sewers, is prohibited by the general permit at all times. The discharge of wash-out water shall not cause or contribute to groundwater contamination.

Concrete trucks will be allowed to wash out or discharge surplus concrete or drum wash water on the site, but only in either specifically designated diked areas which have been prepared to prevent contact between the concrete and wash-out water or storm water which will be discharged from the site; or in locations where waste concrete can be poured into forms to make riprap or other useful concrete products.

The hardened residue from the concrete wash-out diked areas will be disposed of in the same manner as other non-hazardous construction waste materials, or may be broken up and used on site as deemed appropriate by the Contractor. The job site superintendent will be responsible for seeing that these procedures are followed.

F. SPILL PREVENTION PRACTICES

In addition to the good housekeeping and material management practices discussed in previous sections of this plan, the following practices will be followed for spill prevention and cleanup.

MEDINA RIVER SEWER OUTFALL: SEGMENT 4 (SAWS JOB #12-2504)

Storm Water Pollution Prevention Plan

- Manufacturer's recommended methods for spill cleanup will be clearly posted, and site personnel will be trained regarding these procedures and the location of the information and cleanup supplies.
- Materials and equipment necessary for spill cleanup will be kept in the on-site material storage area in a spill control and containment kit (containing for example, absorbent materials such as kitty litter or sawdust, acid neutralizing powder, brooms, dust pans, mops, rags, gloves, goggles, plastic and metal trash containers, etc.).
- All spills will be cleaned up immediately after discovery.
- The spill area will be kept well ventilated and personnel will wear appropriate protective clothing to prevent injury from contact with the hazardous substances.
- Spills of toxic or hazardous materials will be reported to the appropriate federal, state, and local government agency. Spills of amounts that exceed Reportable Quantities of certain substances specifically mentioned in federal regulations (40 CFR 302) will be immediately reported to the TCEQ National Response Center, telephone 1-800-832-8224. Reportable Quantities of some substances which may be used at the job site are as follows:
 - Oil – appearance of a film or sheen on water
 - Pesticides – usually one (1) pound
 - Acids – 5,000 pounds
 - Solvents, flammable – 100 pounds
- The SPCC plan will be adjusted to include measures on how to prevent this type of spill from recurring. A description of the spill, what caused it, and the cleanup measures will also be included. If the spill exceeds a Reportable Quantity, reports of the incident will be in compliance with federal, state, and local regulations.

MEDINA RIVER SEWER OUTFALL: SEGMENT 4 (SAWS JOB #12-2504)
Storm Water Pollution Prevention Plan

- The job site superintendent will be the spill prevention and cleanup coordinator. He will designate the individuals responsible for a particular phase of prevention and cleanup.

EXHIBITS

ATTACHMENTS

**MEDINA RIVER SEWER OUTFALL
SEGMENT 4 (SAWS JOB #12-2504)
Storm Water Pollution Prevention Plan**



SEE SHEET 2 OF 2

Date: Oct 20, 2011, 5:18pm User ID: ROlivera
File: P:\68\66\00\Design\Environmental\SWPPP\Bid Pkg 4\TP686600-4_EX1.dwg

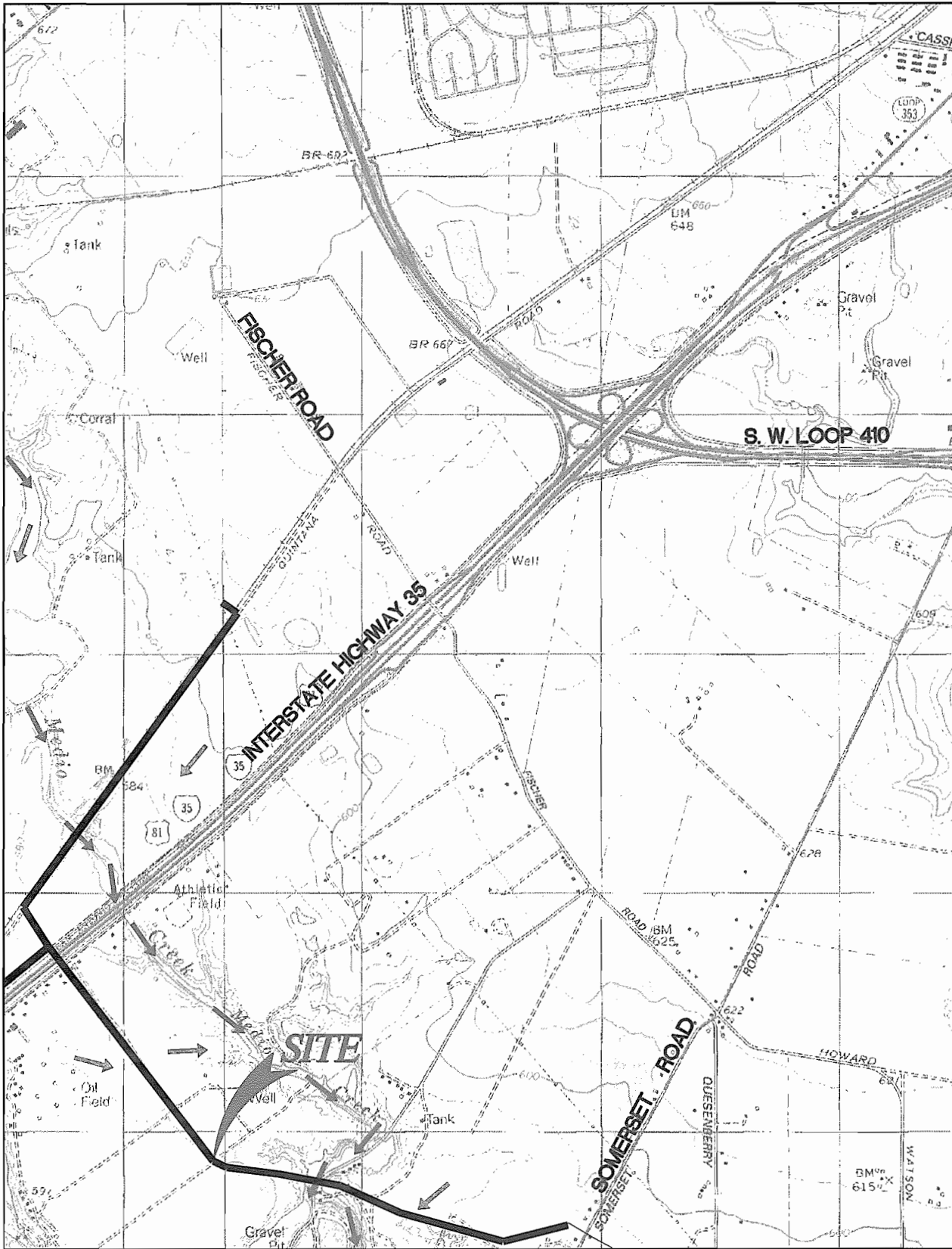

➔➔ DRAINAGE FLOW

EXHIBIT 1

GENERAL LOCATION MAP, MACDONA, TX QUAD,
TERRELL WELLS, TX QUAD
SCALE: 1" = 2000'

Sheet 1 Of 2



**MEDINA RIVER SEWER OUTFALL
SEGMENT 4 (SAWS JOB #12-2504)
Storm Water Pollution Prevention Plan**

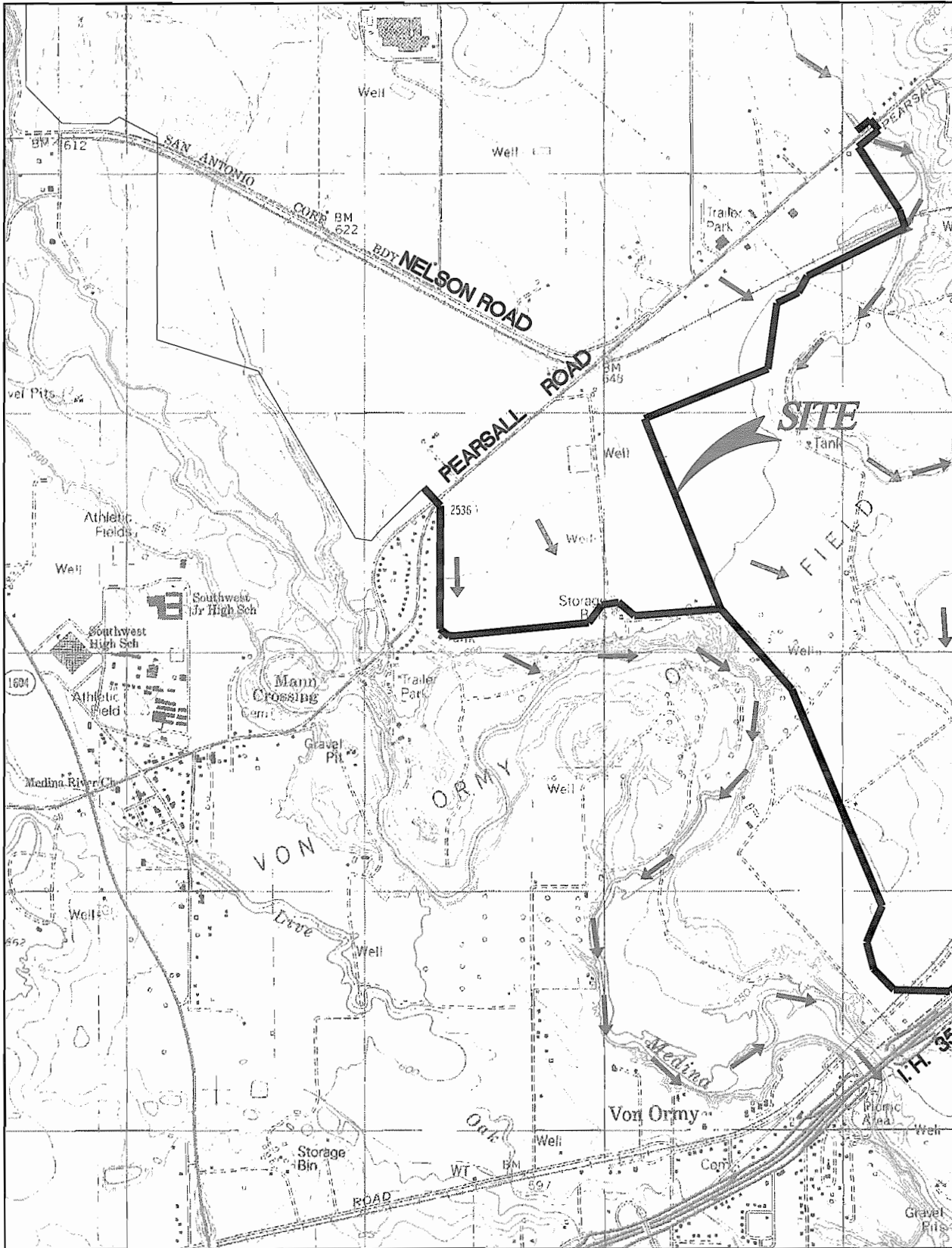

SEE SHEET 1 OF 2

Date: Oct 20, 2011, 5:18pm User: ID: ROLLWAZ
File: P:\66\66\00\Design\Environmental\SMP\PP\4-EX1.dwg

→ → DRAINAGE FLOW

EXHIBIT 1

GENERAL LOCATION MAP, MACDONA, TX QUAD,
TERRELL WELLS, TX QUAD
SCALE: 1" = 2000'

Sheet 2 Of 2



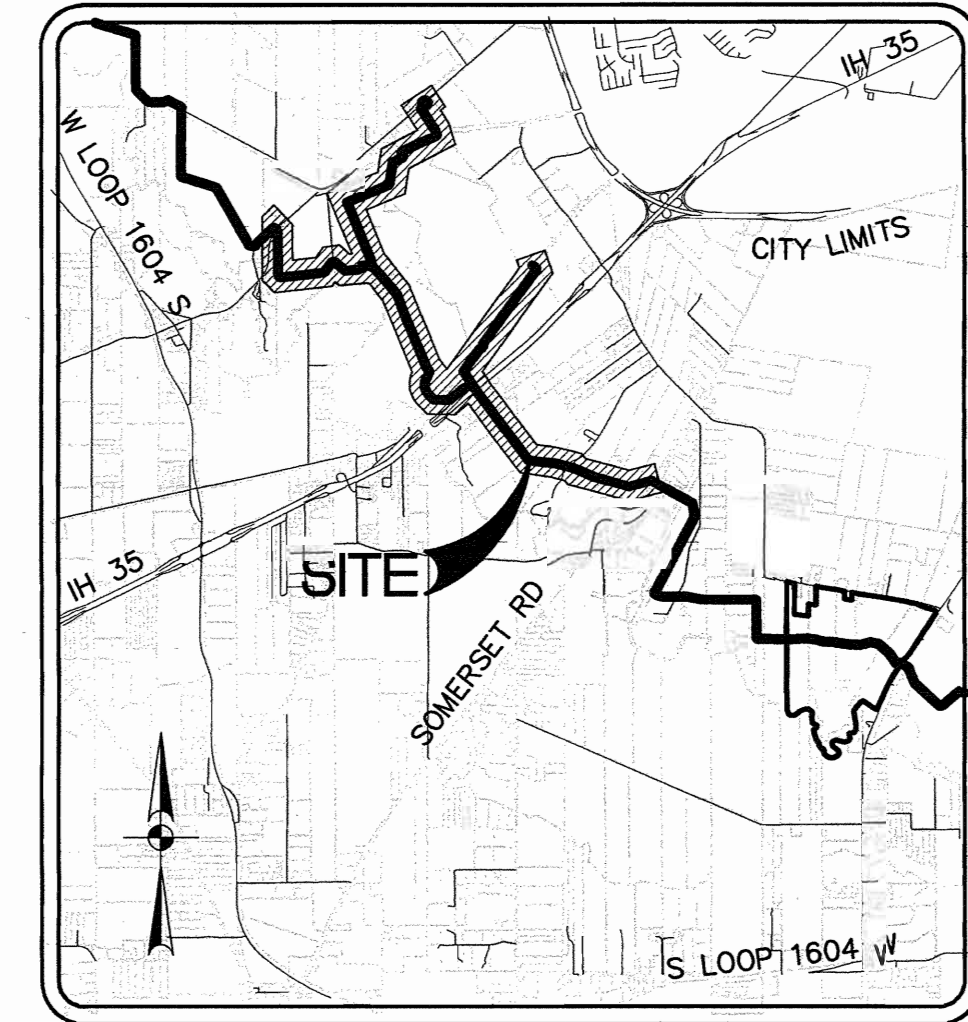

LOCATION MAP
NTS

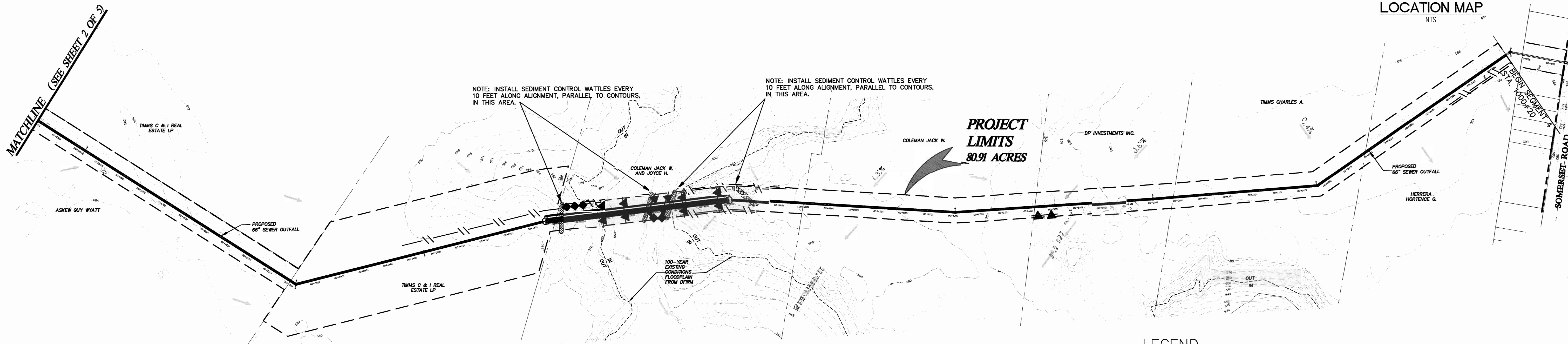

GENERAL NOTES

1. Do not disturb vegetated areas (trees, grass, weeds, brush, etc.) any more than necessary for construction.
2. Construction entrance/exit location, concrete wash-out pit, and construction equipment and material storage yard to be determined in the field.
3. Storm Water Pollution Prevention Controls may need to be modified in the field to accomplish the desired effect. All modifications are to be noted on this Exhibit and signed and dated by the responsible party.
4. Restrict entry/exit to the project site to designated locations by use of adequate fencing, if necessary.
5. All Storm Water Pollution Prevention Controls are to be maintained and in working conditions at all times.
6. For a complete listing of Temporary Storm Water Pollution Prevention Controls refer to the TPDES Storm Water Pollution Prevention Plan.
7. Storm water pollution prevention structures should be constructed within the site boundaries. Some of these features may be shown outside the site boundaries on this plan for visual clarity.
8. As soon as practical, all disturbed soil will be stabilized per applicable project specifications.
9. Best Management Practices may be installed in stages to coincide with the disturbance of upgradient areas.
10. Best Management Practices may be removed in stages once the watershed for that portion controlled by the Best Management Practices has been stabilized in accordance with TPDES requirements.
11. Upon completion of the project, including site stabilization, and before final payment is issued, Contractor shall remove all sediment & erosion control measures, paying special attention to rock berms in drainage features.
12. Prior to beginning construction, Contractor shall coordinate placement of temporary Best Management Practices within TXDOT Right-of-Way with TXDOT.
- *13. Where BMP's are not specified downgradient of disturbed area, due to minimal slope across the easement or the absence of downstream development, Contractor is to maintain vegetation on the downstream side of these areas. If sufficient vegetation cannot be maintained, Contractor is to install silt fence to prevent sediment dispersion outside the easement area.

LEGEND

- PROJECT LIMITS
 - - - FLOODPLAIN
 - - - EXISTING GRADE
 - FLOW ARROW
- TEMPORARY STABILIZATION MEASURES**
- SILT FENCE
 - ▨ SEDIMENT CONTROL WATTLES
 - ▲▲▲ TRIANGULAR SILT DIKE
 - ◆◆◆ ROCK BERM
 - INLET PROTECTION
 - GRAVEL FILTER BAGS
 - ▨ STABILIZED CONSTRUCTION ENTRANCE/EXIT (FIELD LOCATE)
 - ▨ CONSTRUCTION EQUIPMENT, VEHICLE & MATERIALS STORAGE AREA. (FIELD LOCATE)
 - ▨ CONCRETE TRUCK WASH-OUT PIT (FIELD LOCATE)
- FINAL STABILIZATION MEASURES**
- HYDOMULCH (REFERENCE PROJECT SPECIFICATIONS)
 - ▨ EROSION CONTROL MAT & TACKIFIED HYDOMULCH (REFERENCE PROJECT SPECIFICATIONS)

SWP3 MODIFICATIONS

DATE	SIGNATURE	DESCRIPTION

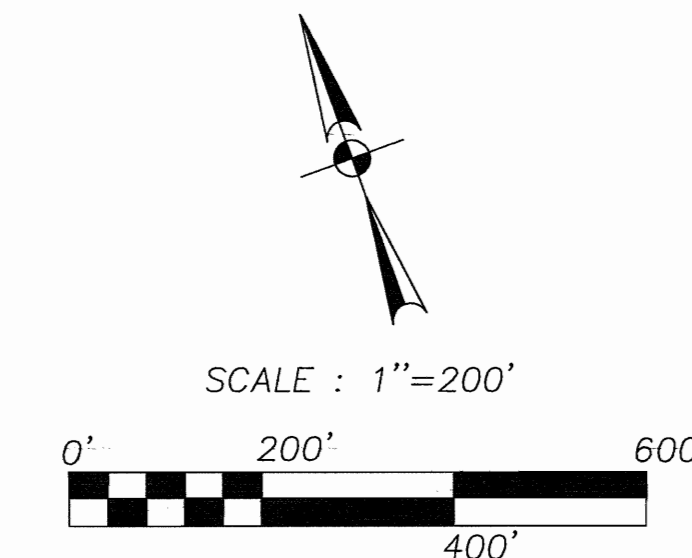

REVISIONS:
10 - CHANGED "BID PACKAGE"
TO "SEGMENT"
- ADDED SLOPES
- NOTE 13 ADDED



PAPE-DAWSON ENGINEERS
SAN ANTONIO, TEXAS 78216 | PHONE: 210.375.9000
555 EAST RAMSEY | SAN ANTONIO, TEXAS 78216 | FAX: 210.375.9010
TEXAS BOARD OF PROFESSIONAL ENGINEERS, FIRM REGISTRATION # 470

**MEDINA RIVER SEWER OUTFALL
SAN ANTONIO, TEXAS
SEGMENT 4, SAWS JOB NO. 12-2504
STORM WATER POLLUTION PREVENTION PLAN**

JOB NO. 6866-00
DATE NOVEMBER 2009
DESIGNER MGB
CHECKED OFF DRAWN RO
SHEET 1 of 5

THE ENGINEERING SEAL HAS BEEN AFFIXED TO THIS SHEET ONLY FOR THE PURPOSE OF DEMONSTRATING COMPLIANCE WITH THE TPDES-STORM WATER POLLUTION PREVENTION PLAN (SWP3) REGULATIONS. THIS SHEET HAS BEEN PREPARED FOR PURPOSES OF THE SWP3 ONLY. ALL OTHER CIVIL ENGINEERING RELATED INFORMATION SHOULD BE ACQUIRED FROM THE APPROPRIATE SHEET IN THE CIVIL IMPROVEMENT PLANS.

EXHIBIT 2

Date: Oct 20, 2011, 4:46pm User: R01lvarez File: F:\05\05\00\Design\Environmental\SWP3\12-2504.dwg

THIS DOCUMENT HAS BEEN PRODUCED FROM MATERIAL THAT WAS STORED AND/OR TRANSMITTED ELECTRONICALLY AND MAY HAVE BEEN INADVERTENTLY ALTERED. RELY ONLY ON FINAL HARDCOPY MATERIALS BEARING THE CONSULTANT'S ORIGINAL SIGNATURE AND SEAL.

GENERAL NOTES

- Do not disturb vegetated areas (trees, grass, weeds, brush, etc.) any more than necessary for construction.
- Construction entrance/exit location, concrete wash-out pit, and construction equipment and material storage yard to be determined in the field.
- Storm Water Pollution Prevention Controls may need to be modified in the field to accomplish the desired effect. All modifications are to be noted on this Exhibit and signed and dated by the responsible party.
- Restrict entry/exit to the project site to designated locations by use of adequate fencing, if necessary.
- All Storm Water Pollution Prevention Controls are to be maintained and in working conditions at all times.
- For a complete listing of Temporary Storm Water Pollution Prevention Controls refer to the TPDES Storm Water Pollution Prevention Plan.
- Storm water pollution prevention structures should be constructed within the site boundaries. Some of these features may be shown outside the site boundaries on this plan for visual clarity.
- As soon as practical, all disturbed soil will be stabilized per applicable project specifications.
- Best Management Practices may be installed in stages to coincide with the disturbance of upgradient areas.
- Best Management Practices may be removed in stages once the watershed for that portion controlled by the Best Management Practices has been stabilized in accordance with TPDES requirements.
- Upon completion of the project, including site stabilization, and before final payment is issued, Contractor shall remove all sediment & erosion control measures, paying special attention to rock berms in drainage features.
- Prior to beginning construction, Contractor shall coordinate placement of temporary Best Management Practices within TXDOT Right-of-Way with TXDOT.
- Where BMP's are not specified downgradient of disturbed area, due to minimal slope across the easement or the absence of downstream development, Contractor is to maintain vegetation on the downstream side of these areas. If sufficient vegetation cannot be maintained, Contractor is to install silt fence to prevent sediment dispersion outside the easement area.

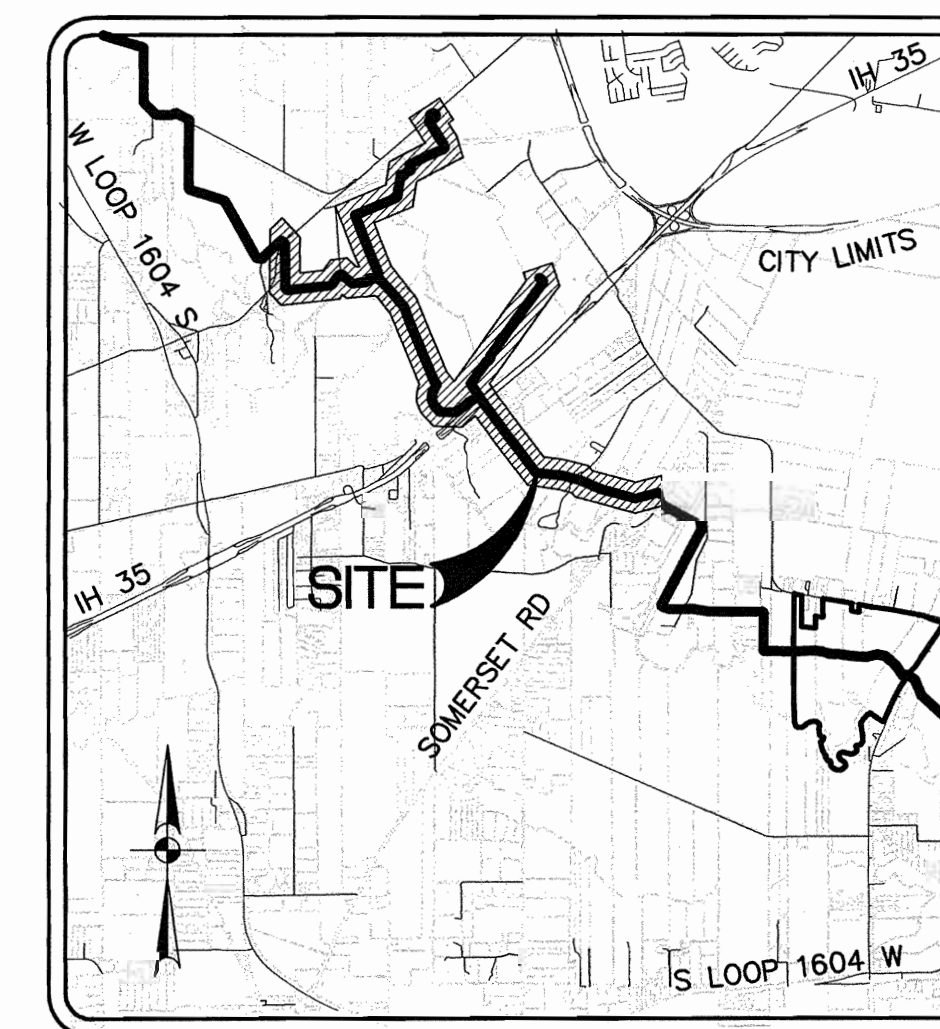

LOCATION MAP
NTS

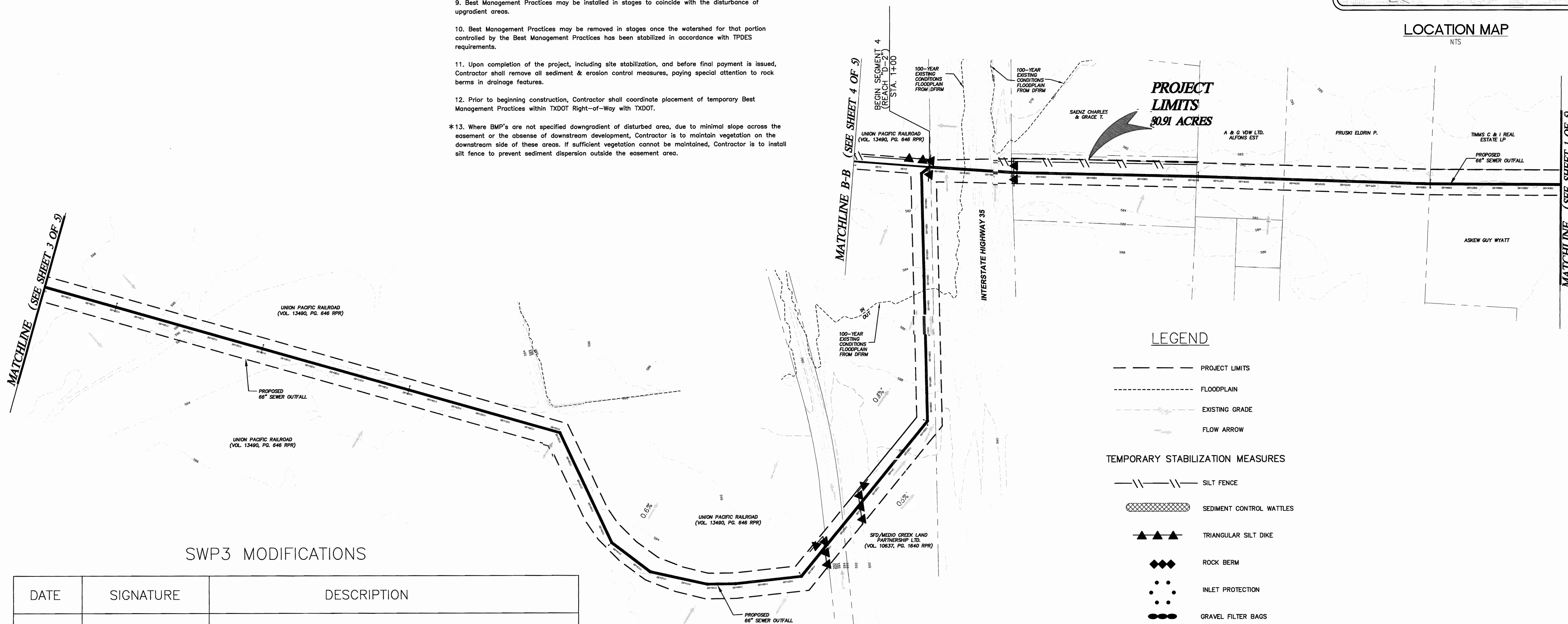

SWP3 MODIFICATIONS

LEGEND

- PROJECT LIMITS
 - FLOODPLAIN
 - EXISTING GRADE
 - FLOW ARROW
- TEMPORARY STABILIZATION MEASURES**
- SILT FENCE
 - SEDIMENT CONTROL WATTLES
 - TRIANGULAR SILT DIKE
 - ROCK BERM
 - INLET PROTECTION
 - GRAVEL FILTER BAGS
 - STABILIZED CONSTRUCTION ENTRANCE/EXIT (FIELD LOCATE)
 - CONSTRUCTION EQUIPMENT, VEHICLE & MATERIALS STORAGE AREA (FIELD LOCATE)
 - CONCRETE TRUCK WASH-OUT PIT (FIELD LOCATE)
- FINAL STABILIZATION MEASURES**
- HYDROMULCH (REFERENCE PROJECT SPECIFICATIONS)
 - EROSION CONTROL MAT & TACKIFIED HYDROMULCH (REFERENCE PROJECT SPECIFICATIONS)

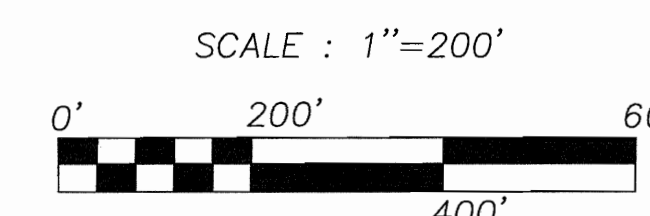
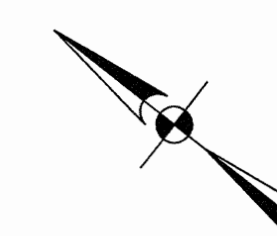

DATE	SIGNATURE	DESCRIPTION

THE ENGINEERING SEAL HAS BEEN AFFIXED TO THIS SHEET ONLY FOR THE PURPOSE OF DEMONSTRATING COMPLIANCE WITH THE TPDES-STORM WATER POLLUTION PREVENTION PLAN (SWP3) REGULATIONS.

THIS SHEET HAS BEEN PREPARED FOR PURPOSES OF THE SWP3 ONLY. ALL OTHER CIVIL ENGINEERING RELATED INFORMATION SHOULD BE ACQUIRED FROM THE APPROPRIATE SHEET IN THE CIVIL IMPROVEMENT PLANS.

EXHIBIT 2

REVISIONS:
10-14-2011
-CHANGED BID PACKAGE*
-ADDED SLOPES
-NOTE 13 ADDED

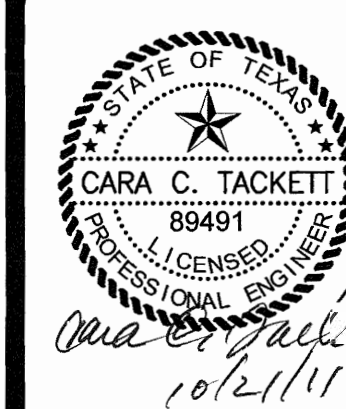

PAPE-DAWSON ENGINEERS
555 EAST RAMSEY | SAN ANTONIO, TEXAS 78216 | PHONE: 210.375.9000
FAX: 210.375.9010
TEXAS BOARD OF PROFESSIONAL ENGINEERS, FIRM REGISTRATION # 470

**MEDINA RIVER SEWER OUTFALL
SAN ANTONIO, TEXAS
SEGMENT 4, SAWS JOB NO. 12-2504
STORM WATER POLLUTION PREVENTION PLAN**

JOB NO. 8866-00
DATE NOVEMBER 2009
DESIGNER MGB
CHECKED CPF DRAWN RO
SHEET 2 of 5

Date: Oct 20, 2011, 4:45pm User: ID: R0lvarez File: P:\G8\105\105\Design\Environmental\SWP3\B1.Pkg 4\TPDES6600-L_E12.dwg

THIS DOCUMENT HAS BEEN PRODUCED FROM MATERIAL THAT WAS STORED AND/OR TRANSMITTED ELECTRONICALLY AND MAY HAVE BEEN INADVERTENTLY ALTERED. RELY ONLY ON FINAL HARD COPY MATERIALS BEARING THE CONSULTANT'S ORIGINAL SIGNATURE AND SEAL.

Date: 06-20-2011 4:45pm User ID: R01110001
 File: P:\104566100\Design\Environmental\SWP3\Bld_Plg_41\TP686600-4_E32.dwg

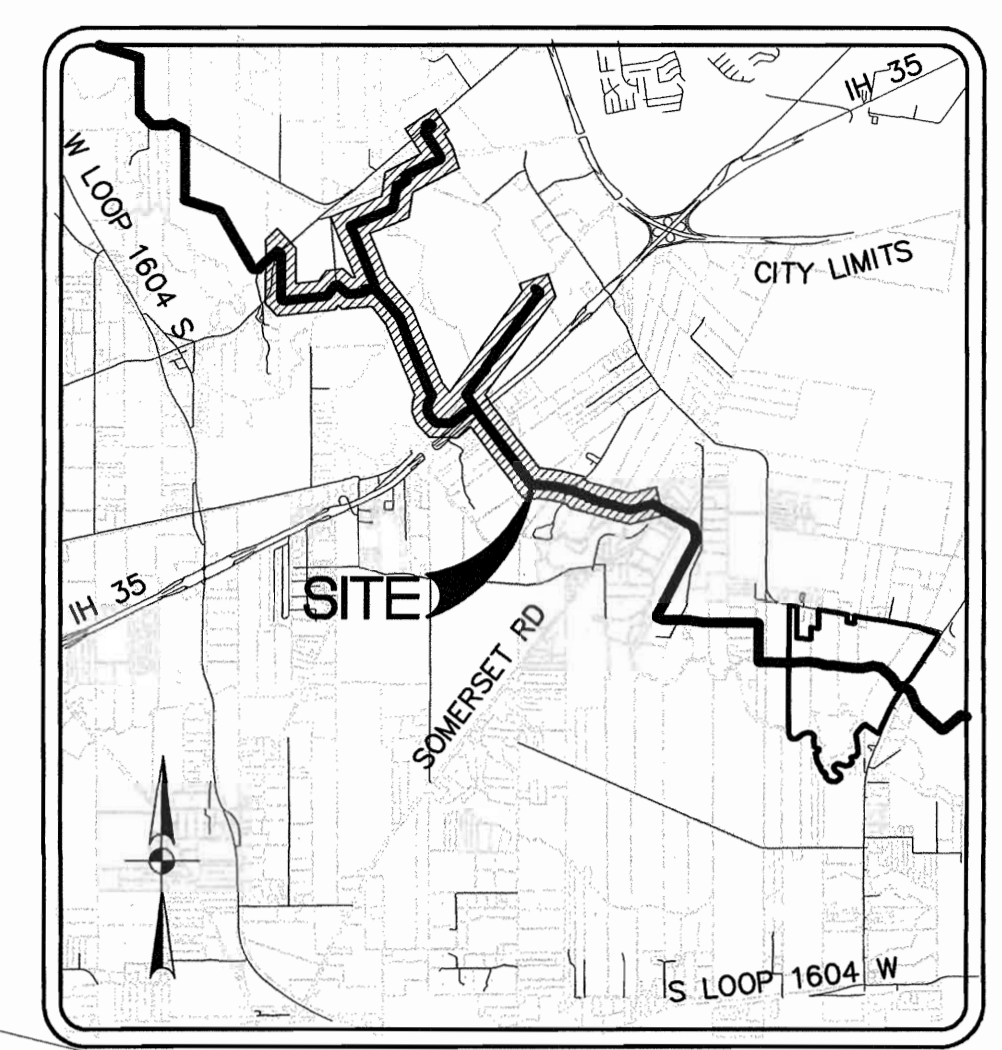
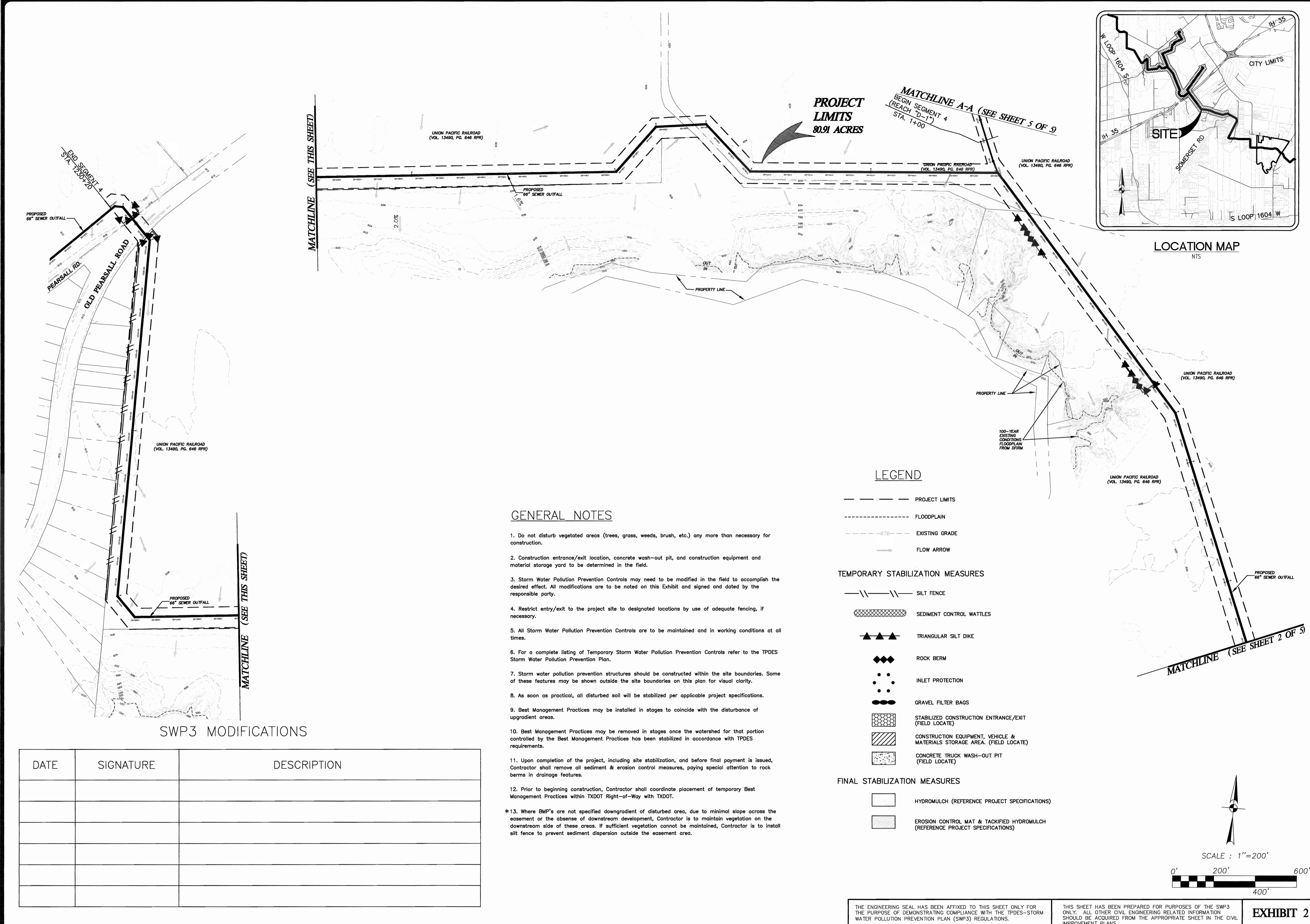

LOCATION MAP
NTS

LEGEND

- PROJECT LIMITS
- - - FLOODPLAIN
- - - - - EXISTING GRADE
- FLOW ARROW
- TEMPORARY STABILIZATION MEASURES**
- ||| SILT FENCE
- ▨ SEDIMENT CONTROL WATTLES
- ▲▲▲ TRIANGULAR SILT DIKE
- ◆◆◆ ROCK BERM
- INLET PROTECTION
- GRAVEL FILTER BAGS
- ▨ STABILIZED CONSTRUCTION ENTRANCE/EXIT (FIELD LOCATE)
- ▨ CONSTRUCTION EQUIPMENT, VEHICLE & MATERIALS STORAGE AREA (FIELD LOCATE)
- ▨ CONCRETE TRUCK WASH-OUT PIT (FIELD LOCATE)
- FINAL STABILIZATION MEASURES**
- HYDROMULCH (REFERENCE PROJECT SPECIFICATIONS)
- ▨ EROSION CONTROL MAT & TACKIFIED HYDROMULCH (REFERENCE PROJECT SPECIFICATIONS)

GENERAL NOTES

1. Do not disturb vegetated areas (trees, grass, weeds, brush, etc.) any more than necessary for construction.
2. Construction entrance/exit location, concrete wash-out pit, and construction equipment and material storage yard to be determined in the field.
3. Storm Water Pollution Prevention Controls may need to be modified in the field to accomplish the desired effect. All modifications are to be noted on this Exhibit and signed and dated by the responsible party.
4. Restrict entry/exit to the project site to designated locations by use of adequate fencing, if necessary.
5. All Storm Water Pollution Prevention Controls are to be maintained and in working conditions at all times.
6. For a complete listing of Temporary Storm Water Pollution Prevention Controls refer to the TPDES Storm Water Pollution Prevention Plan.
7. Storm water pollution prevention structures should be constructed within the site boundaries. Some of these features may be shown outside the site boundaries on this plan for visual clarity.
8. As soon as practical, all disturbed soil will be stabilized per applicable project specifications.
9. Best Management Practices may be installed in stages to coincide with the disturbance of upgradient areas.
10. Best Management Practices may be removed in stages once the watershed for that portion controlled by the Best Management Practices has been stabilized in accordance with TPDES requirements.
11. Upon completion of the project, including site stabilization, and before final payment is issued, Contractor shall remove all sediment & erosion control measures, paying special attention to rock berms in drainage features.
12. Prior to beginning construction, Contractor shall coordinate placement of temporary Best Management Practices within TXDOT Right-of-Way with TXDOT.
- *13. Where BMP's are not specified downgradient of disturbed area, due to minimal slope across the easement or the absence of downstream development, Contractor is to maintain vegetation on the downstream side of these areas. If sufficient vegetation cannot be maintained, Contractor is to install silt fence to prevent sediment dispersion outside the easement area.

SWP3 MODIFICATIONS

DATE	SIGNATURE	DESCRIPTION

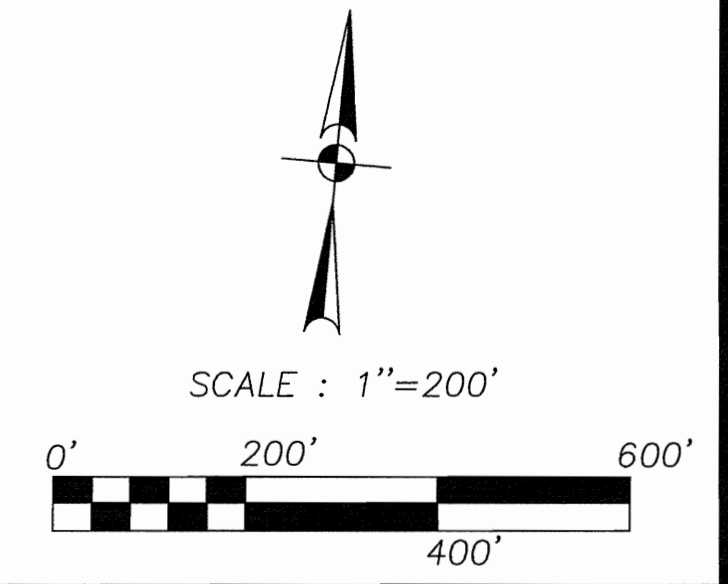

THE ENGINEERING SEAL HAS BEEN AFFIXED TO THIS SHEET ONLY FOR THE PURPOSE OF DEMONSTRATING COMPLIANCE WITH THE TPDES-STORM WATER POLLUTION PREVENTION PLAN (SWP3) REGULATIONS.

THIS SHEET HAS BEEN PREPARED FOR PURPOSES OF THE SWP3 ONLY. ALL OTHER CIVIL ENGINEERING RELATED INFORMATION SHOULD BE ACQUIRED FROM THE APPROPRIATE SHEET IN THE CIVIL IMPROVEMENT PLANS.

EXHIBIT 2

REVISIONS:
 10-14-2011 BID PACKAGE
 -TO "SEGMENT"
 -ADDED SLOPES
 -NOTE 13 ADDED

STATE OF TEXAS
 CARA C. TACKETT
 8848
 LICENSED PROFESSIONAL ENGINEER
Cara C. Tackett
 10/21/11

PAPE-DAWSON ENGINEERS
 SAN ANTONIO, TEXAS 78216 | PHONE: 210.375.9000
 555 EAST RAMSEY | SAN ANTONIO, TEXAS 78216 | FAX: 210.375.9010
 TEXAS BOARD OF PROFESSIONAL ENGINEERS, FIRM REGISTRATION # 470

**MEDINA RIVER SEWER OUTFALL
 SAN ANTONIO, TEXAS
 SEGMENT 4, SAWS JOB NO. 12-2504
 STORM WATER POLLUTION PREVENTION PLAN**

JOB NO. 6866-00
 DATE NOVEMBER 2009
 DESIGNER MGB
 CHECKED CPE DRAWN RO
 SHEET 3 of 5

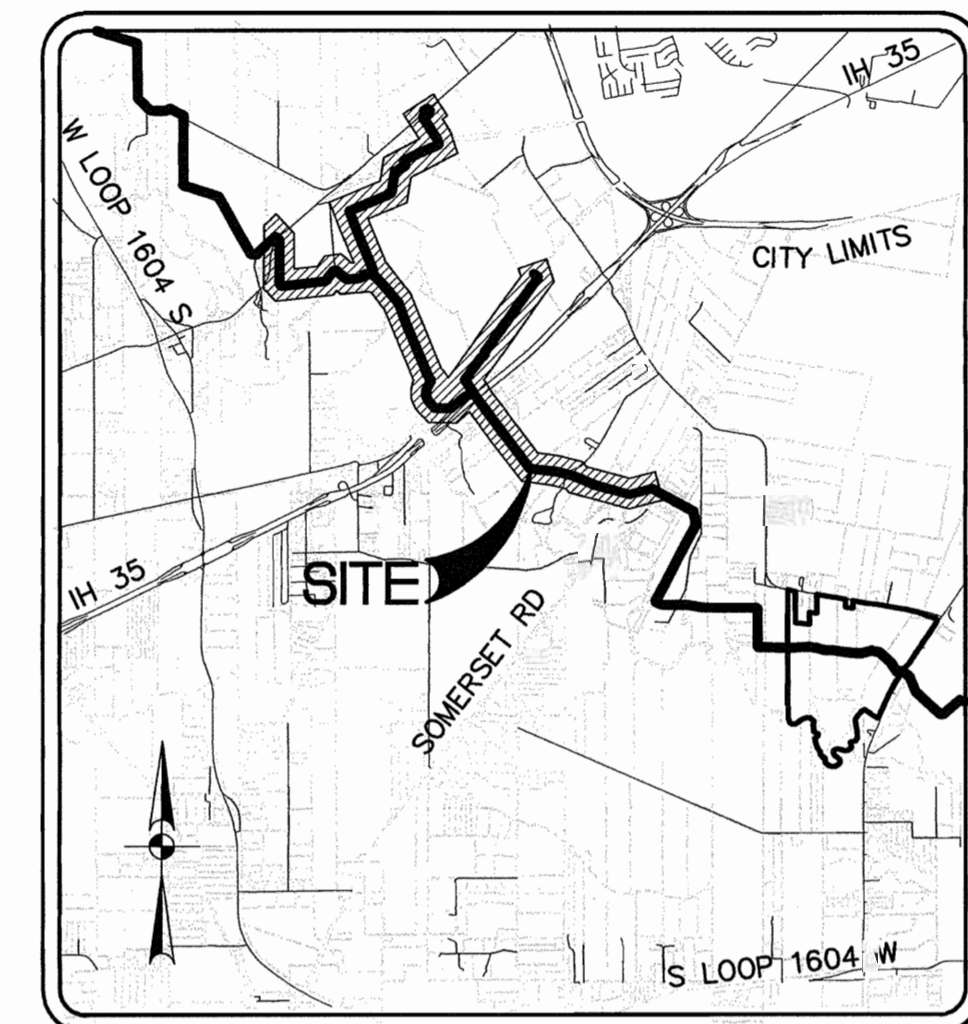

LOCATION MAP
NTS

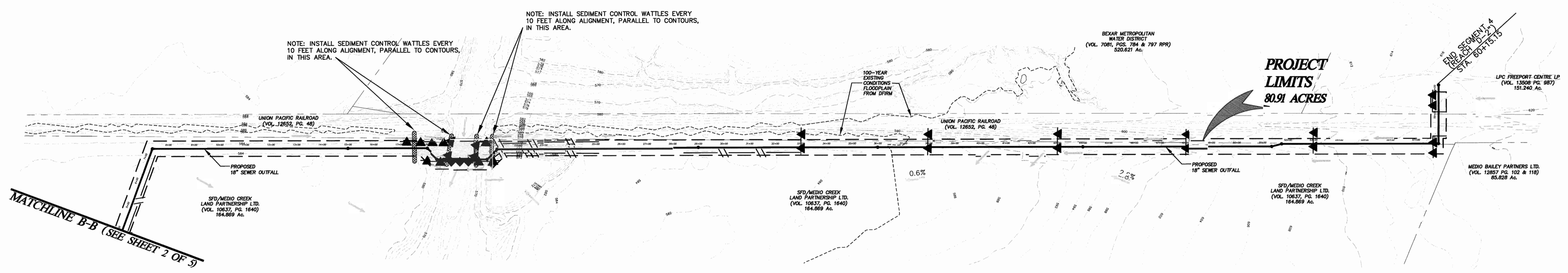

MATCHLINE B-B (SEE SHEET 2 OF 5)

GENERAL NOTES

- Do not disturb vegetated areas (trees, grass, weeds, brush, etc.) any more than necessary for construction.
- Construction entrance/exit location, concrete wash-out pit, and construction equipment and material storage yard to be determined in the field.
- Storm Water Pollution Prevention Controls may need to be modified in the field to accomplish the desired effect. All modifications are to be noted on this Exhibit and signed and dated by the responsible party.
- Restrict entry/exit to the project site to designated locations by use of adequate fencing, if necessary.
- All Storm Water Pollution Prevention Controls are to be maintained and in working conditions at all times.
- For a complete listing of Temporary Storm Water Pollution Prevention Controls refer to the TPDES Storm Water Pollution Prevention Plan.
- Storm water pollution prevention structures should be constructed within the site boundaries. Some of these features may be shown outside the site boundaries on this plan for visual clarity.
- As soon as practical, all disturbed soil will be stabilized per applicable project specifications.
- Best Management Practices may be installed in stages to coincide with the disturbance of upgradient areas.
- Best Management Practices may be removed in stages once the watershed for that portion controlled by the Best Management Practices has been stabilized in accordance with TPDES requirements.
- Upon completion of the project, including site stabilization, and before final payment is issued, Contractor shall remove all sediment & erosion control measures, paying special attention to rock berms in drainage features.
- Prior to beginning construction, Contractor shall coordinate placement of temporary Best Management Practices within TXDOT Right-of-Way with TXDOT.
- Where BMP's are not specified downgradient of disturbed area, due to minimal slope across the easement or the absence of downstream development, Contractor is to maintain vegetation on the downstream side of these areas. If sufficient vegetation cannot be maintained, Contractor is to install silt fence to prevent sediment dispersion outside the easement area.

LEGEND

- PROJECT LIMITS
- FLOODPLAIN
- EXISTING GRADE
- FLOW ARROW

TEMPORARY STABILIZATION MEASURES

- SILT FENCE
- SEDIMENT CONTROL WATTLES
- TRIANGULAR SILT DIKE
- ROCK BERM
- INLET PROTECTION
- GRAVEL FILTER BAGS
- STABILIZED CONSTRUCTION ENTRANCE/EXIT (FIELD LOCATE)
- CONSTRUCTION EQUIPMENT, VEHICLE & MATERIALS STORAGE AREA. (FIELD LOCATE)
- CONCRETE TRUCK WASH-OUT PIT (FIELD LOCATE)

FINAL STABILIZATION MEASURES

- HYDROMULCH (REFERENCE PROJECT SPECIFICATIONS)
- EROSION CONTROL MAT & TACKIFIED HYDROMULCH (REFERENCE PROJECT SPECIFICATIONS)

SWP3 MODIFICATIONS

DATE	SIGNATURE	DESCRIPTION

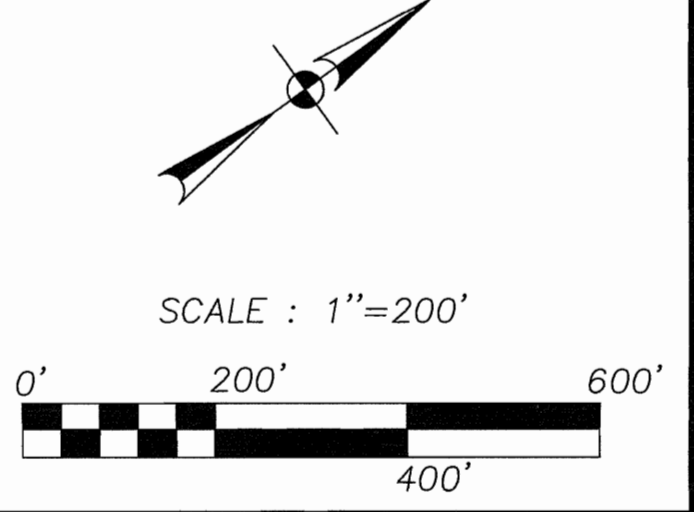

THE ENGINEERING SEAL HAS BEEN AFFIXED TO THIS SHEET ONLY FOR THE PURPOSE OF DEMONSTRATING COMPLIANCE WITH THE TPDES-STORM WATER POLLUTION PREVENTION PLAN (SWP3) REGULATIONS.

THIS SHEET HAS BEEN PREPARED FOR PURPOSES OF THE SWP3 ONLY. ALL OTHER CIVIL ENGINEERING RELATED INFORMATION SHOULD BE ACQUIRED FROM THE APPROPRIATE SHEET IN THE CIVIL IMPROVEMENT PLANS.

EXHIBIT 2

MEDINA RIVER SEWER OUTFALL
SAN ANTONIO, TEXAS
SEGMENT 4, SAWS JOB NO. 12-2504
STORM WATER POLLUTION PREVENTION PLAN

JOB NO. 6866-00
DATE NOVEMBER 2009
DESIGNER MGB
CHECKED CPE DRAWN RO
SHEET 4 of 5

PAPE-DAWSON ENGINEERS
SAN ANTONIO, TEXAS 78216
555 EAST RAMSEY | SAN ANTONIO, TEXAS 78216 | PHONE: 210.375.9000 | FAX: 210.375.9010
TEXAS BOARD OF PROFESSIONAL ENGINEERS, FIRM REGISTRATION # 470

REVISIONS:
- CHANGED "BID PACKAGE" TO "SEGMENT"
- ADDED SLOPES
- NOTE 13 ADDED

CARA C. TACKETT
89481
PROFESSIONAL ENGINEER
10/2/14

THIS DOCUMENT HAS BEEN PRODUCED FROM MATERIAL THAT WAS STORED AND/OR TRANSMITTED ELECTRONICALLY AND MAY HAVE BEEN INADVERTENTLY ALTERED. RELY ONLY ON FINAL HARDCOPY MATERIALS BEARING THE CONSULTANT'S ORIGINAL SIGNATURE AND SEAL.

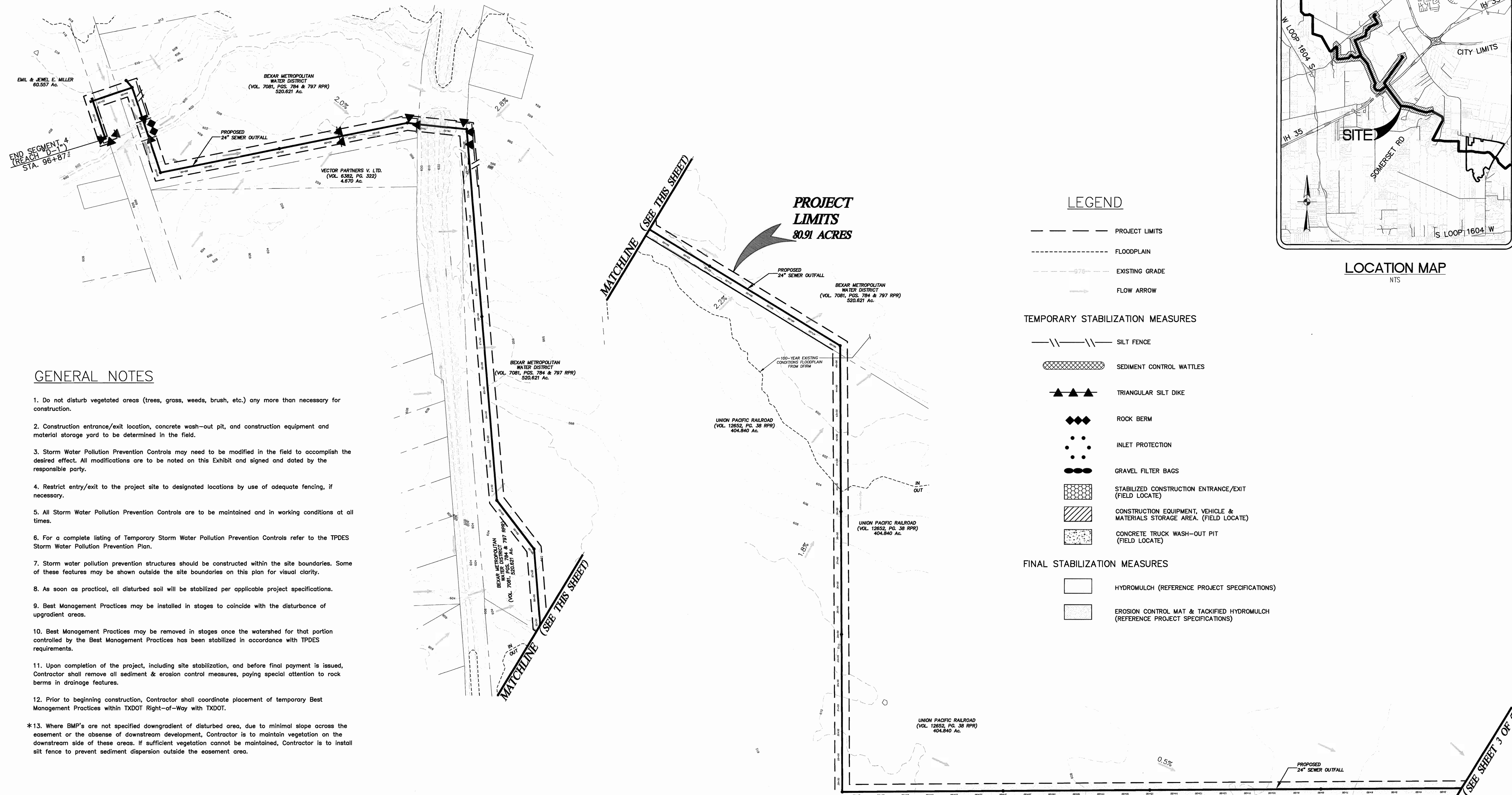

GENERAL NOTES

1. Do not disturb vegetated areas (trees, grass, weeds, brush, etc.) any more than necessary for construction.
2. Construction entrance/exit location, concrete wash-out pit, and construction equipment and material storage yard to be determined in the field.
3. Storm Water Pollution Prevention Controls may need to be modified in the field to accomplish the desired effect. All modifications are to be noted on this Exhibit and signed and dated by the responsible party.
4. Restrict entry/exit to the project site to designated locations by use of adequate fencing, if necessary.
5. All Storm Water Pollution Prevention Controls are to be maintained and in working conditions at all times.
6. For a complete listing of Temporary Storm Water Pollution Prevention Controls refer to the TPDES Storm Water Pollution Prevention Plan.
7. Storm water pollution prevention structures should be constructed within the site boundaries. Some of these features may be shown outside the site boundaries on this plan for visual clarity.
8. As soon as practical, all disturbed soil will be stabilized per applicable project specifications.
9. Best Management Practices may be installed in stages to coincide with the disturbance of upgradient areas.
10. Best Management Practices may be removed in stages once the watershed for that portion controlled by the Best Management Practices has been stabilized in accordance with TPDES requirements.
11. Upon completion of the project, including site stabilization, and before final payment is issued, Contractor shall remove all sediment & erosion control measures, paying special attention to rock berms in drainage features.
12. Prior to beginning construction, Contractor shall coordinate placement of temporary Best Management Practices within TXDOT Right-of-Way with TXDOT.

*13. Where BMP's are not specified downgradient of disturbed area, due to minimal slope across the easement or the absence of downstream development, Contractor is to maintain vegetation on the downstream side of these areas. If sufficient vegetation cannot be maintained, Contractor is to install silt fence to prevent sediment dispersion outside the easement area.

SWP3 MODIFICATIONS

DATE	SIGNATURE	DESCRIPTION

- LEGEND**
- PROJECT LIMITS
 - - - FLOODPLAIN
 - - - EXISTING GRADE
 - FLOW ARROW
- TEMPORARY STABILIZATION MEASURES**
- ||| SILT FENCE
 - ▨ SEDIMENT CONTROL WATTLES
 - ▲ TRIANGULAR SILT DIKE
 - ◆ ROCK BERM
 - INLET PROTECTION
 - GRAVEL FILTER BAGS
 - ▨ STABILIZED CONSTRUCTION ENTRANCE/EXIT (FIELD LOCATE)
 - ▨ CONSTRUCTION EQUIPMENT, VEHICLE & MATERIALS STORAGE AREA. (FIELD LOCATE)
 - ▨ CONCRETE TRUCK WASH-OUT PIT (FIELD LOCATE)
- FINAL STABILIZATION MEASURES**
- ▨ HYDROMULCH (REFERENCE PROJECT SPECIFICATIONS)
 - ▨ EROSION CONTROL MAT & TACKIFIED HYDROMULCH (REFERENCE PROJECT SPECIFICATIONS)

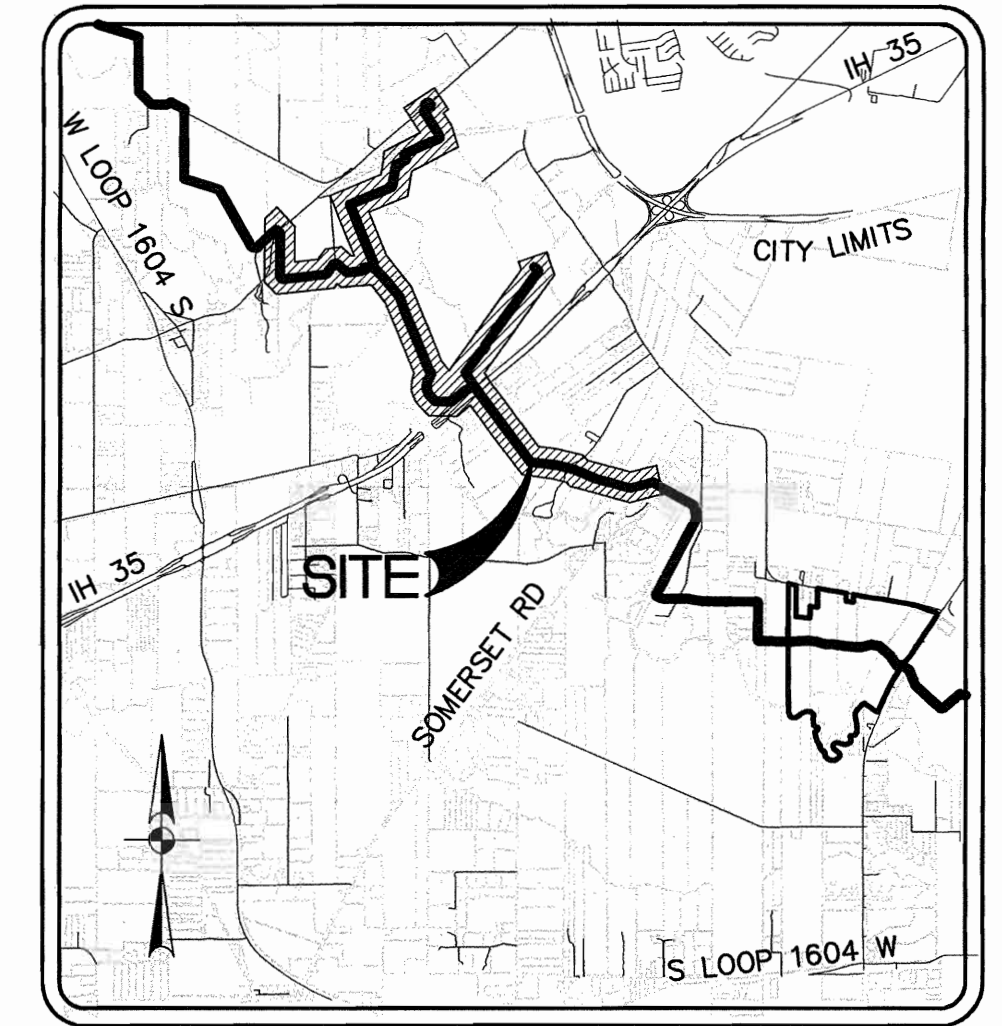

LOCATION MAP
NTS

REVISIONS:
-CHANGED "BID PACKAGE" TO "SEGMENT"
-ADDED SLOPES
-NOTE IS ADDED



PAPE-DAWSON ENGINEERS
555 EAST RAMSEY | SAN ANTONIO, TEXAS 78216 | PHONE: 210.375.9000 | FAX: 210.375.9010
TEXAS BOARD OF PROFESSIONAL ENGINEERS, FIRM REGISTRATION # 470

**MEDINA RIVER SEWER OUTFALL
SAN ANTONIO, TEXAS
SEGMENT 4, SAWS JOB NO. 12-2504
STORM WATER POLLUTION PREVENTION PLAN**

JOB NO. 6866-00
DATE NOVEMBER 2009
DESIGNER MGB
CHECKED CPE DRAWN RO
SHEET 5 of 5

THE ENGINEERING SEAL HAS BEEN AFFIXED TO THIS SHEET ONLY FOR THE PURPOSE OF DEMONSTRATING COMPLIANCE WITH THE TPDES-STORM WATER POLLUTION PREVENTION PLAN (SWP3) REGULATIONS.

THIS SHEET HAS BEEN PREPARED FOR PURPOSES OF THE SWP3 ONLY. ALL OTHER CIVIL ENGINEERING RELATED INFORMATION SHOULD BE ACQUIRED FROM THE APPROPRIATE SHEET IN THE CIVIL IMPROVEMENT PLANS.

EXHIBIT 2

Date: 06-20-2011 4:44pm User: ID: ACivils P: 156166100 Design: Environmental/BMP/PP/1604_SWP3.dwg

THIS DOCUMENT HAS BEEN PRODUCED FROM MATERIAL THAT WAS STORED AND/OR TRANSMITTED ELECTRONICALLY AND MAY HAVE BEEN INADVERTENTLY ALTERED. RELY ONLY ON FINAL HARDCOPY MATERIALS BEARING THE CONSULTANT'S ORIGINAL SIGNATURE AND SEAL.

SILT FENCE
A silt fence is a barrier consisting of geotextile fabric supported by metal posts to prevent soil and sediment loss from a site. When properly used, silt fences can be highly effective at controlling sediment from disturbed areas. They cause runoff to pond, allowing heavier solids to settle out. If not properly installed, silt fences are not likely to be effective.

The purpose of a silt fence is to intercept and detain water-borne sediment from unprotected areas of a limited extent. Silt fence is used during the period of construction near the perimeter of a disturbed area to intercept sediment while allowing water to percolate through. This fence should remain in place until the disturbed area is permanently stabilized. Silt fence should not be used where there is a concentration of water in a channel or drainage way. If concentrated flow occurs after installation, corrective action must be taken such as placing a rock berm in the areas of concentrated flow.

Silt fencing within the site may be temporarily moved during the day to allow construction activity provided it is replaced and properly anchored to the ground at the end of the day. Silt fences on the perimeter of the site or around drainage ways should not be moved at any time.

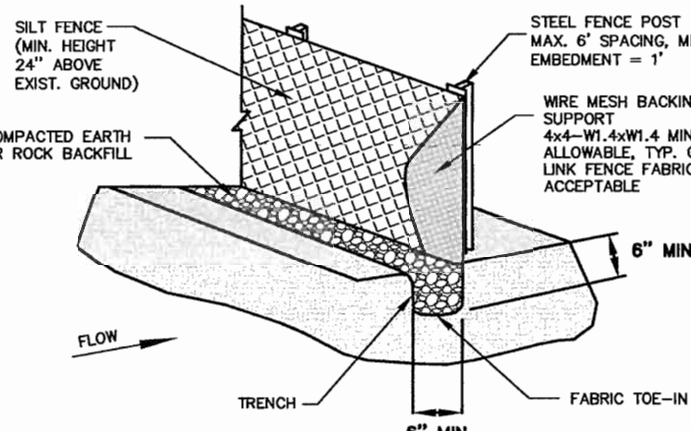

ISOMETRIC PLAN VIEW
N.T.S.

Schematic of a Silt Fence Installation (NCTCOG, 1993b)

SILT FENCE

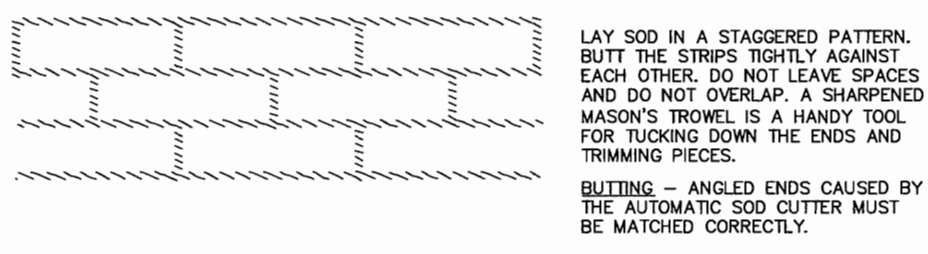

APPEARANCE OF GOOD SOD

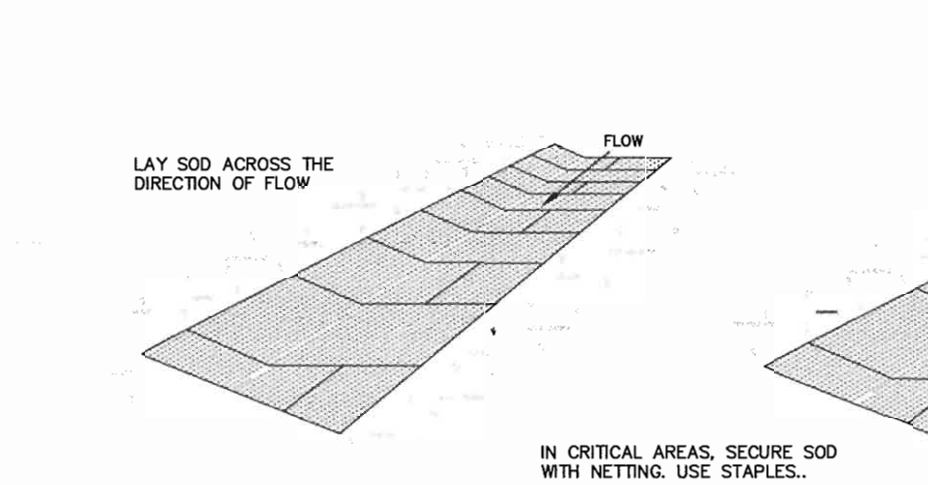

USE PEGS OR STAPLES TO FASTEN SOD FIRMLY - AT THE ENDS OF STRIPS AND IN THE CENTER, OR EVERY 3-4 FEET IF THE STRIPS ARE LONG, WHEN READY TO MAKE PEGS OR STAPLES FLUSH WITH THE GROUND.

- Materials:**
- Sod should be machine cut to a uniform soil thickness of 3/4" inch (± 1/4" inch) at the time of cutting. This thickness should exclude shoot growth and thatch.
 - Pieces of sod should be cut to the supplier's standard width and length, with a maximum allowable deviation in any dimension of 5%. Torn or uneven pads should not be acceptable.
 - Standard size sections of sod should be strong enough to support their own weight and retain their size and shape when suspended from a firm grasp on one end of the section.
 - Sod should be harvested, delivered, and installed within a period of 36 hours.

- Site Preparation:**
- Prior to sod preparation, areas to be sodded should be brought to final grade in accordance with the approved plan.
 - The surface should be cleared of all trash, debris and of all roots, brush, wire, grade stakes and other objects that would interfere with planting, fertilizing or maintenance operations.
 - Fertilize according to soil tests. Fertilizer needs can be determined by a soil testing laboratory or regional recommendations can be made by county agricultural extension agents. Fertilizer should be worked into the soil to a depth of 3 inches with a disc, springtooth harrow or other suitable equipment. On sloping land, the final harrowing or discing operation should be on the contour.

- Installation in Channels:**
- Sod strips in waterways should be laid perpendicular to the direction of flow. Care should be taken to butt ends of strips tightly (see Figure above).
 - After rolling or tamping, sod should be pegged or stapled to resist washout during the establishment period. Mesh or other netting may be pegged over the sod for extra protection in critical areas.

- General Installation (VA Dept. of Conservation, 1992):**
- Sod should not be cut or laid in excessively wet or dry weather. Sod should not be laid on soil surfaces that are frozen.
 - During periods of high temperature, the soil should be lightly irrigated immediately prior to laying the sod, to cool the soil and reduce root burning and dieback.
 - The first row of sod should be laid in a straight line with subsequent rows placed parallel to and butting tightly against each other. Lateral joints should be staggered to provide more uniform growth and strength. Care should be exercised to ensure that sod is not stacked or overlapped and that all joints are butted tight in order to prevent voids which would cause drying of the roots (see above).
 - On slopes 3:1 or greater, or wherever erosion may be a problem, sod should be laid with staggered joints and secured by stapling or other approved methods. Sod should be installed with the length perpendicular to the slope (on contour).
 - As sodding of clearly defined areas is completed, sod should be rolled or tamped to provide firm contact between roots and soil.
 - After rolling, sod should be irrigated to a depth sufficient that the underside of the sod pod and the soil 4 inches below the sod is thoroughly wet.
 - Until such time as a good root system becomes developed, in the absence of adequate rainfall, watering should be performed as often as necessary to maintain moist soil to a depth of at least 4 inches.
 - The first mowing should not be attempted until the sod is firmly rooted, usually 2-3 weeks. Not more than one third of the grass leaf should be removed at any one cutting.
- Inspection and Maintenance Guidelines:**
- Sod should be inspected weekly and after each rain event to locate and repair any damage.
 - Damage from storms or normal construction activities such as tire ruts or disturbance of swale stabilization should be repaired as soon as practicable.

SOD INSTALLATION

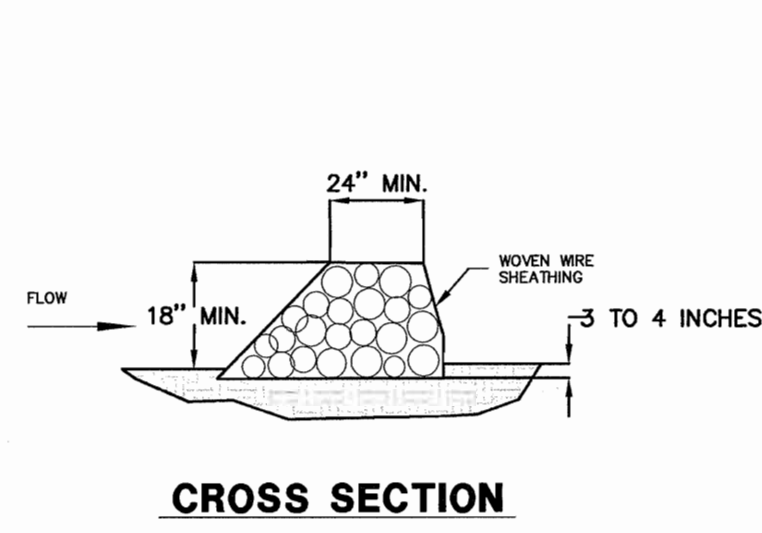

CROSS SECTION
N.T.S.

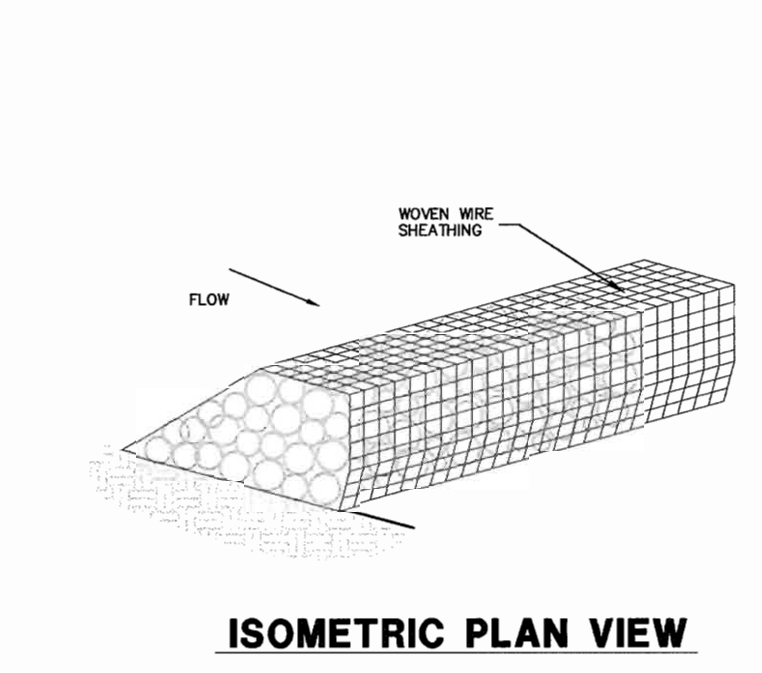

ISOMETRIC PLAN VIEW
N.T.S.

Schematic Diagram of a Rock Berm (NCTCOG, 1993)

ROCK BERMS
The purpose of a rock berm is to serve as a check dam in areas of concentrated flow, to intercept sediment-laden runoff, detain the sediment and release the water in sheet flow. The rock berm should be used when the contributing drainage area is less than 5 acres. Rock berms are used in areas where the volume of runoff is too great for a silt fence to contain. They are less effective for sediment removal than silt fences, particularly for fine particles, but are able to withstand higher flows than a silt fence. As such, rock berms are often used in areas of channel flows (ditches, gullies, etc.). Rock berms are most effective at reducing bed load in channels and should not be substituted for other erosion and sediment control measures further up the watershed.

- MATERIALS:**
- The berm structure should be secured with a woven wire sheathing or chain-link fencing, 1 inch and a minimum wire diameter of 20 gauge galvanized and should be secured with stout rings.
 - Clean, open graded 3- to 5-inch diameter rock should be used, except in areas where high velocities and large volumes of flow are expected, where 3- to 8-inch diameter rocks may be used.

- INSTALLATION:**
- Lay out the woven wire sheathing perpendicular to the flow line. The sheathing should be 20 gauge woven wire mesh with 1 inch openings.
 - Berm should have a top width of 2 feet minimum with side slopes being 2:1 (H:V) or flatter.
 - Place the rock along the sheathing as shown in the diagram to a height not less than 18".
 - Wrap the wire sheathing around the rock and secure with tie wire so that the ends of the sheathing overlap at least 2 inches, and the berm retains its shape when walked upon.
 - Berm should be built along the contour at zero percent grade or as near as possible.
 - The ends of the berm should be tied into existing upslope grade and the berm should be buried in a trench approximately 3 to 4 inches deep to prevent failure of the control.

- COMMON TROUBLE POINTS:**
- Insufficient berm height or length (runoff quickly escapes over the top or around the sides of berm).
 - Berm not installed perpendicular to flow line (runoff escaping around one side).

- INSPECTION AND MAINTENANCE GUIDELINES:**
- Inspection should be made weekly and after each rainfall by the responsible party. For installations in streambeds, additional daily inspections should be made.
 - Remove sediment and other debris when buildup reaches 6 inches and dispose of the accumulated silt in an approved manner that will not cause any additional siltation.
 - Repair any loose wire sheathing.
 - The berm should be reshaped as needed during inspection.
 - The berm should be replaced when the structure ceases to function as intended due to silt accumulation among the rocks, washout, construction traffic damage, etc.
 - The rock berm should be left in place until all upstream areas are stabilized and accumulated silt removed.

ROCK BERM

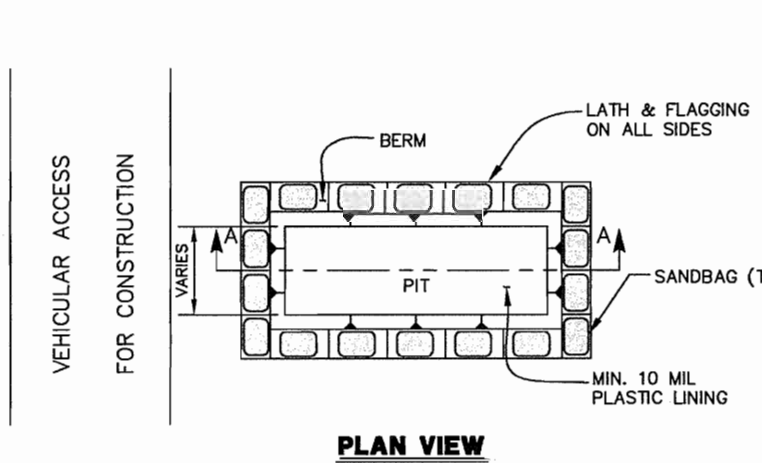

PLAN VIEW

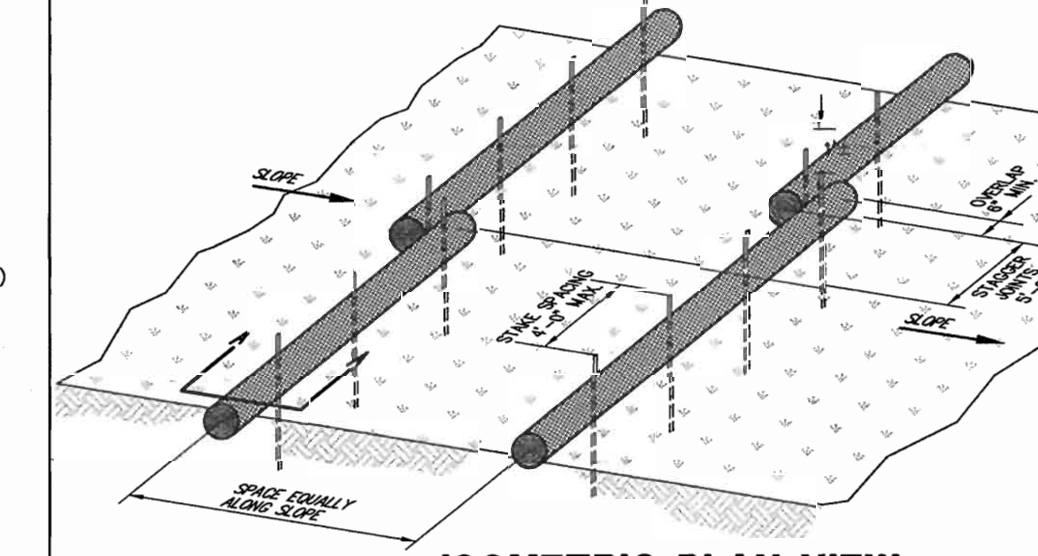

ISOMETRIC PLAN VIEW
N.T.S.

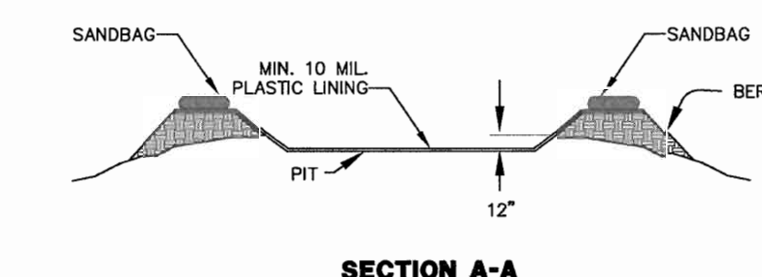

SECTION A-A

WATTLES
Wattles are elongated tubes of compacted straw and/or other fibers that are installed along contours or at the base of slopes to help reduce soil erosion and retain sediment. They function by shortening slope length, reducing runoff water velocity, trapping dislodged soil particles and reducing the effects of slope steepness.

MATERIALS
Core material: Core materials shall be biodegradable and non-toxic weed free. Material may be compost, mulch, open excelsior wood fibers, chipped site vegetation, agricultural rice or wheat straw, coconut fiber, or other 100% biodegradable fibers. Containment mesh: containment mesh shall be 100% biodegradable, photodegradable or recyclable such as burlap twine, UV photodegradable plastic or polyester. Use biodegradable or photodegradable mesh when wattle will remain in place as part of a vegetative system. Use recyclable mesh for temporary installations.

INSTALLATION

- Remove all rocks, clods, vegetation or other obstructions so that the installed Wattles will have direct contact with the soil.
- A small trench, 2-4 inches in depth should be excavated on the slope contour and perpendicular to water flow. Soil from the excavation should be placed upside next to the trench.
- Install the Wattles in the trench, insuring that no gaps exist between the soil and the bottom of the Wattle. Wattles should be lapped 6" minimum to prevent sediment passing through the field joint.
- Wooden stakes should be used to fasten the Wattles to the soil. When conditions warrant, a straight metal bar can be used to drive a "pilot hole" through the Wattle and into the soil.
- Wooden stakes should be placed 6" from the Wattle end angled towards the adjacent Wattle and spaced at 4 feet centers leaving less than 1-2 inches of stake exposed above the Wattle. Alternately, stakes may be placed on each side of the Wattle tying across with a natural fiber twine or staking in a crossing manner ensuring direct soil contact at all times.
- Terminal ends of Wattles may be "dog legged" up slope to ensure containment and prevent channeling of sediment.
- Backfill the upslope length of the Wattle with the excavated soil and compact.
- Care shall be taken during installation so as to avoid damage occurring to the Wattle as a result of the installation process. Should the Wattle be damaged during installation, a wooden stake shall be placed either side of the damaged area terminating the log segment.

GENERAL NOTES:

- Detail above illustrates minimum dimensions. Pit can be increased in size depending on expected frequency of use.
- Washout pit shall be located in an area easily accessible to construction traffic.
- Washout pit shall not be located in areas subject to inundation from storm water runoff.
- Locate washout area at least 50 feet from sensitive features, storm drains, open ditches, or water bodies.
- Temporary concrete washout facility should be constructed with sufficient quantity and volume to contain all liquid and concrete waste generated by washout operations.

MATERIALS:

- Plastic lining material should be a minimum of 10 mil in polyethylene sheeting and should be free of holes, tears, or other defects that compromise the impermeability of the material.

MAINTENANCE:

- When temporary concrete washout facilities are no longer required for the work, the hardened concrete should be removed and disposed of.
- Materials used to construct temporary concrete washout facilities should be removed from the site of the work and disposed of.

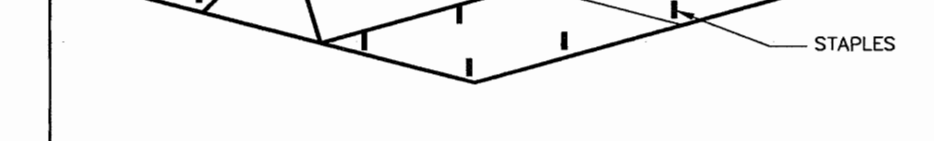

TRIANGULAR SILT DIKES

CONCRETE TRUCK WASHOUT PIT

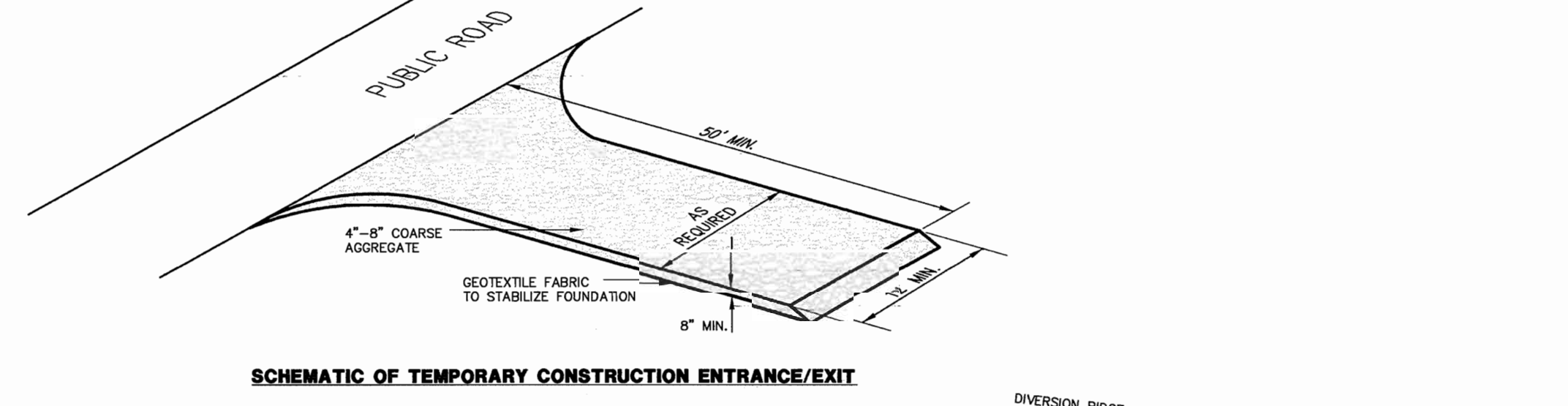

SCHEMATIC OF TEMPORARY CONSTRUCTION ENTRANCE/EXIT

- MATERIALS:**
- The aggregate should consist of 4 to 8 inch washed stone over a stable foundation as specified in the plan.
 - The aggregate should be placed with a minimum thickness of 8 inches.
 - The geotextile fabric should be designed specifically for use as a soil filtration media with an approximate weight of 6 oz/yd², a mullen burst rating of 140 lb/ft², and an equivalent opening size greater than a number 50 sieve.
 - If a washing facility is required, a level area with a minimum of 4 inch diameter washed stone or commercial rock should be included in the plan. Divert wastewater to a sediment trap or basin.

- INSTALLATION:**
- Avoid curves on public roads and steep slopes. Remove vegetation and other objectionable material from the foundation area. Grade crown foundation for positive drainage.
 - The minimum width of the entrance/exit should be 12 feet or the full width of exit roadway, whichever is greater.
 - The construction entrance should be at least 50 feet long.
 - If the slope toward the road exceeds 2%, construct a ridge, 6 to 8 inches high with 3:1 (H:V) side slopes, across the foundation approximately 15 feet from the entrance to divert runoff away from the public road.

- Place geotextile fabric and grade foundation to improve stability, especially where wet conditions are anticipated.
- Place stone to dimensions and grade shown on plans. Leave surface smooth and slope for drainage.
- Divert all surface runoff and drainage from the stone pad to a sediment trap or basin.
- Install pipe under pad as needed to maintain proper public road drainage.

STABILIZED CONSTRUCTION ENTRANCE/EXIT

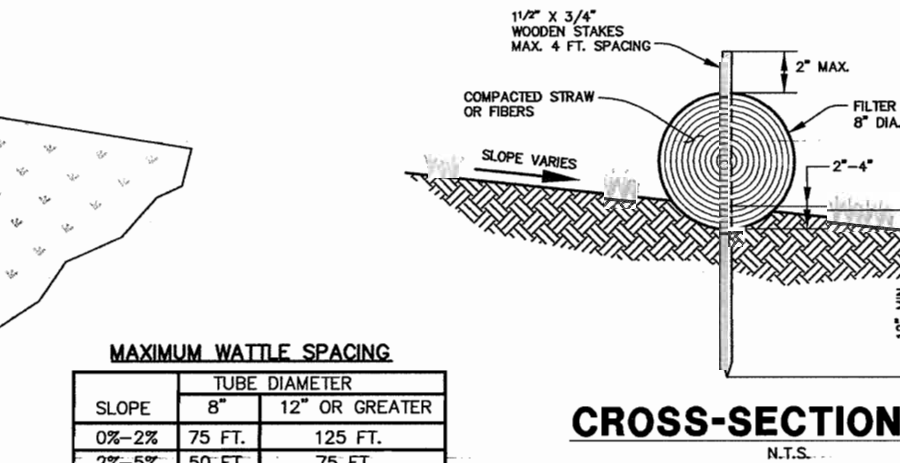

CROSS-SECTION 'A-A'
N.T.S.

MAXIMUM WATTLE SPACING

SLOPE	TUBE DIAMETER	MAXIMUM SPACING
OR-2%	8"	75 FT.
2%-5%	12" OR GREATER	125 FT.
5%-10%	8"	75 FT.
10%+	12" OR GREATER	50 FT.

- INSPECTION AND MAINTENANCE**
- The Wattles shall be inspected after installation to insure that they are tranced-in and that no gaps exist under the Wattles or between adjacent ends of the Wattles.
 - Wattles shall be inspected after significant rainfall events. Rills or gullies upslope of the Wattle and any undercutting is to be repaired.
 - Trenches, depressions or any other ground disturbances caused by the removal of the temporary straw Wattles shall be backfilled and repaired with the excess sediment captured by the Wattle, prior to spreading the straw or other final erosion control protection.

WATTLES IN A PERMANENT EROSION CONTROL APPLICATION
Leave Wattles as installed to photodegrade or biodegrade over time as native and applied vegetation ultimately stabilize the repaired site.

SEDIMENT CONTROL WATTLES

MATERIALS
The triangular-shaped inner material shall be urethane foam. The outer cover shall be a woven geotextile fabric placed around the inner material and allowed to extend beyond both sides of the triangle two to three (2-3') feet.

- INSTALLATION**
- The triangular silt fence dike as required.
 - Attach dikes to the ground with staples as indicated on the detail.

- MAINTENANCE**
- Inspect after each storm event.
 - Remove built-up sediment and repair/replace the silt dikes as needed.



THE ENGINEERING SEAL HAS BEEN AFFIXED TO THIS SHEET ONLY FOR THE PURPOSE OF DEMONSTRATING COMPLIANCE WITH THE TPDES-STORM WATER POLLUTION PREVENTION PLAN (SWP3) REGULATIONS.

CROSS-SECTION OF A CONSTRUCTION ENTRANCE/EXIT

- COMMON TROUBLE POINTS:**
- Inadequate runoff control-sediment washes onto public road.
 - Stone too small or geotextile fabric absent, results in muddy condition as stone is pressed into soil.
 - Pad too short for heavy construction traffic-extend pad beyond the minimum 50 foot length as necessary.
 - Pad not flared sufficiently at road surface, results in mud being tracked on to road and possible damage to road.
 - Unstable foundation - use geotextile fabric under pad and/or improve foundation drainage.

- INSPECTION AND MAINTENANCE GUIDELINES:**
- The entrance should be maintained in a condition, which will prevent tracking or flowing of sediment onto public rights-of-way. This may require periodic top dressing with additional stone as conditions demand and repair and/or cleanout of any measures used to trap sediment.
 - All sediment spilled, dropped, washed or tracked onto public rights-of-way should be removed immediately by contractor.
 - When necessary, wheels should be cleaned to remove sediment prior to entrance onto public right-of-way.
 - When washing is required, it should be done on an area stabilized with crushed stone that drains into an approved sediment trap or sediment basin.
 - All sediment should be prevented from entering any storm drain, ditch or water course by using approved methods.

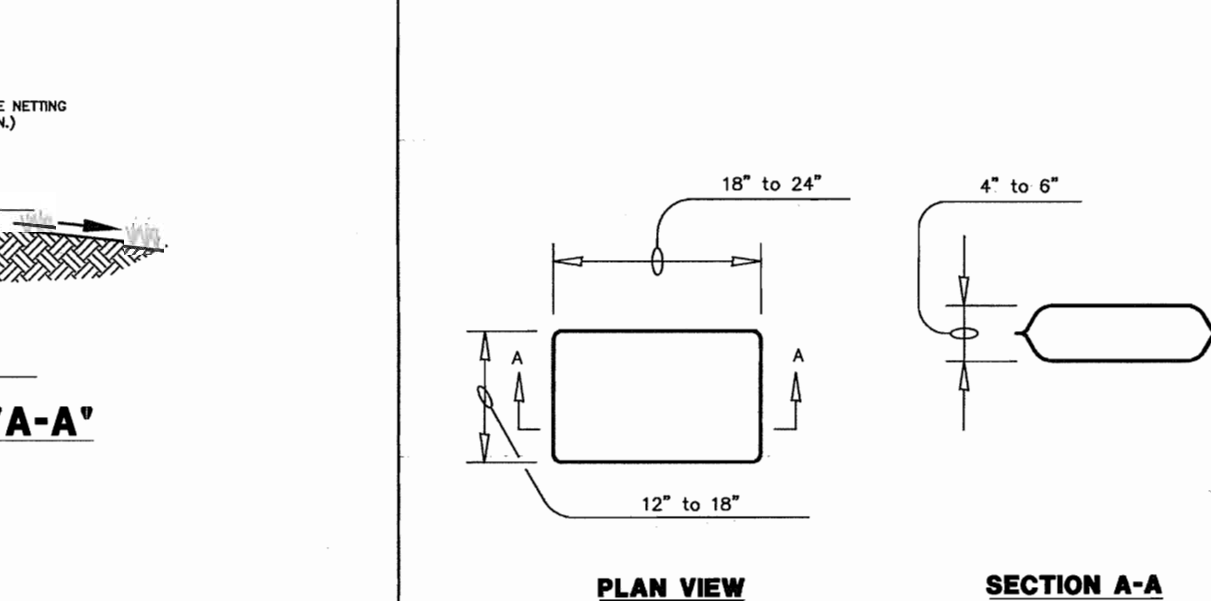

SECTION A-A

- GRAVEL FILTER BAG DETAIL**
- The filter bag material shall be made of polypropylene, polyethylene or polyamide woven fabric, min. unit weight of 4 ounces/sy, have a Mullen burst strength exceeding 300 psi and ultraviolet stability exceeding 70%.
 - The filter bag shall be filled with clean, medium (washed pea gravel) to coarse gravel (0.31 to 0.75 inch diameter).
 - Sand shall NOT be used to fill the filter bags.

CONSTRUCTION STAGING AREA

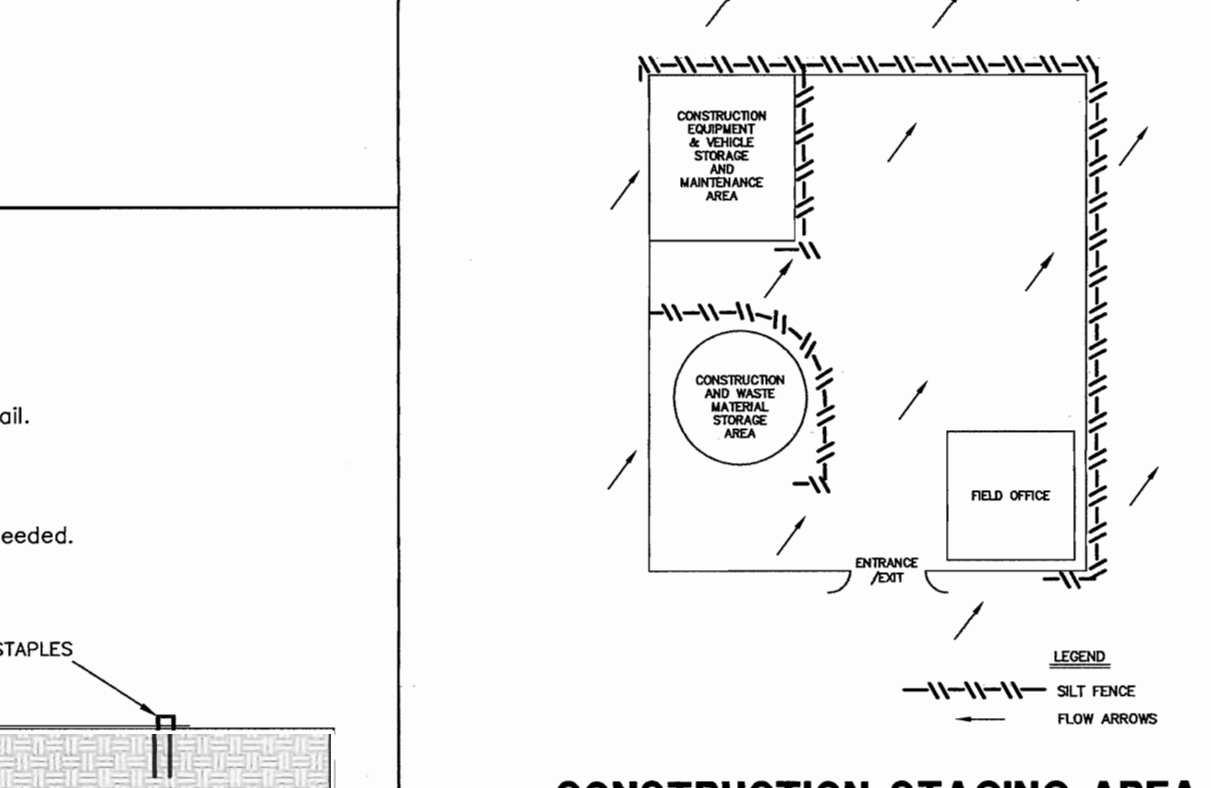

CONSTRUCTION STAGING AREA

REVISIONS:
10-14-2011
-CHANGED "BIG PACKAGE"
TO "SEGMENT"
-ADDED
-TO BOTTOM OF SHEET

PAPE-DAWSON ENGINEERS
555 EAST RAMSEY | SAN ANTONIO, TEXAS 78216 | PHONE: 210.375.9000 FAX: 210.375.9010 TEXAS BOARD OF PROFESSIONAL ENGINEERS, FIRM REGISTRATION # 470

MEDINA RIVER SEWER OUTFALL SAN ANTONIO, TEXAS
SEGMENT 4, SAWS JOB NO. 12-2504
STORM WATER POLLUTION PREVENTION PLAN
DETAIL SHEET

JOB NO. 6866-00
DATE NOVEMBER 2009
DESIGNER MGB
CHECKED CPE DRAWN RO
SHEET 1 OF 1

EXHIBIT 3

Date: Oct 20, 2011, 5:11pm User: DR: R010varez
File: P:\198\103\103\Design\Environmental\SWPPP\Blr_Plg_4_TPD\1686600-4_EJ3.dwg

MEDINA RIVER SEWER OUTFALL: SEGMENT 4 (SAWS JOB #12-2504)
Storm Water Pollution Prevention Plan

PROJECT MILESTONE DATES

Date when major site grading activities begin:

<u>Construction Activity</u>	<u>Date</u>
Installation of BMPs	

Dates when construction activities temporarily or permanently cease on all or a portion of the project:

<u>Construction Activity</u>	<u>Date</u>

Dates when stabilization measures are initiated:

<u>Stabilization Activity</u>	<u>Date</u>
Removal of BMPs	

MEDINA RIVER SEWER OUTFALL: SEGMENT 4 (SAWS JOB #12-2504)
Storm Water Pollution Prevention Plan

TPDES GENERAL PERMIT TXR150000

RESPONSIBLE PARTY FORM

SHARED STORM WATER POLLUTION PREVENTION PLAN

I certify under penalty of law that this document and all attachments were prepared under my direction or supervision in accordance with a system designed to assure that qualified personnel properly gather and evaluate the information submitted. Based on my inquiry of the person or persons who manage the system, or those persons directly responsible for gathering the information, the information submitted is, to the best of my knowledge and belief, true, accurate, and complete. I am aware there are significant penalties for submitting false information, including the possibility of fine and imprisonment for knowing violations.

I further certify that I am authorized under 30 Texas Administrative Code §305.44 to sign and submit this document, and can provide documentation in proof of such authorization upon request.

Primary Operator having operational control over construction plans and specifications, including the ability to make modifications to these plans and specifications.

Entity Name: _____

Authorized Signature/Date: _____

Name and Position: _____

Permit No.: _____

Secondary Operator whose operational control is limited to the employment of other operators or to the ability to approve or disapprove changes to plans and specifications.

Entity Name: _____

Authorized Signature/Date: _____

Name and Position: _____

Permit No.: _____

Owner Information

Owner Name: _____

Authorized Signature/Date: _____

Name and Position: _____

Permit No.: _____

Primary Operator having day-to-day operational control of those construction site activities necessary to ensure compliance with the Storm Water Pollution Prevention Plan or other permit conditions.

Company Name: _____

Authorized Signature/Date: _____

Name and Position: _____

Permit No.: _____

MEDINA RIVER SEWER OUTFALL: SEGMENT 4 (SAWS JOB #12-2504)
Storm Water Pollution Prevention Plan

TPDES GENERAL PERMIT TXR150000
RESPONSIBLE PARTY FORM

Prevention Measure Pollution 1. Responsible Party 2. Signature 3. Phone Number																	
	i	i	i	i	i	i	i	i	i	i	i	i	i	i	i	i	i

Best Management Practices																	
SWP3 Modification & Records																	
Natural vegetation buffer strip																	
Temporary vegetation																	
Permanent vegetation																	
Sediment control basin																	
Silt fences																	
Rock berms																	
Gravel filter bags																	
Drain inlet protection																	
Other structural controls																	
Vehicle exits (off-site tracking)																	
Material storage areas (leakage)																	
Equipment areas (leaks, spills)																	
Concrete washout pit (leaks, failure)																	
Construction debris																	
General site cleanliness																	
Trash receptacles																	
Inspections																	

Potential Erosion Sources																	
Clearing																	
Grading																	
Excavation																	
Drainage construction																	
Utility construction																	
Roadway or parking lot construction																	
Foundation construction																	
Building construction																	
Landscaping activities																	

Identify responsible parties and indicate responsible party for each pollution prevention item listed above by marking an X under the Responsible Party Name.

**NOTICE OF INTENT,
CONSTRUCTION SITE NOTICE
& NOI TRACKING FORM**



**Notice of Intent (NOI) for Storm Water
Discharges Associated with Construction
Activity under TPDES General Permit
(TXR150000)**

TCEQ Office Use Only
Permit No.: TXR15
RN:
CN:
Ref No:



**Sign up now for ePermits NOI at www6.tceq.state.tx.us/steers
Get Instant Permit Coverage and only pay a \$225 application fee.**

If filing a paper NOI you can pay the application fee on line? Go to www.tceq.state.tx.us/epay
Select Fee Type: GENERAL PERMIT CONSTRUCTION STORM WATER DISCHARGE NOI APPLICATION
If submitting a paper NOI, coverage under the general permit starts seven (7) days after the date postmarked for delivery to TCEQ.

IMPORTANT:

- Use the **INSTRUCTIONS** to fill out each question in this form.
- Use the attached **CUSTOMER CHECKLIST** to make certain all you filled out all required information.
- Incomplete applications **WILL** delay approval or result in **automatic Denial**.

Renewal of General Permit

Is this NOI to renew an ACTIVE permit?

- Yes - What is your permit number? Permit No. TXR15 _____
 No - a permit number will be issued.

Application Fee if mailing a paper NOI:

You must pay the \$325 Application Fee to TCEQ for the application to be considered complete.
Payment and NOI must be mailed to separate addresses. See instructions for correct mailing addresses.

Provide your payment information below, for us to verify payment of the application fee:

<input type="checkbox"/> Mailed:	Check/Money Order No.:	Company Name on checking account:
<input type="checkbox"/> EPAY:	Voucher No.:	Is the Payment Voucher copy attached? <input type="checkbox"/> Yes

A. OPERATOR (applicant)

1. If the applicant is currently a customer with TCEQ, what is the Customer Number (CN) issued to this entity?
CN 600529069 (Search Central Registry)

2. What is the Legal Name of the entity (applicant) applying for this permit?
San Antonio Water System

(The legal name must be spelled exactly as filed with the Texas Secretary of State, County, or in the legal document forming the entity.)

3. What is the name and title of the person signing the application?
 (The person must be an official meeting signatory requirements in TAC 305.43(a).)

Name:	Job Title:
-------	------------

4. What is the Operator's (applicant) mailing address as recognized by the **US Postal Service?** (verify at USPS.com)

Address: 2800 U.S Highway 281 North	Suite No./Bldg. No./Mail Code:
City: San Antonio	State: Texas ZIP Code: 78212
Country Mailing Information (if outside USA):	Country Code: Postal Code:

5. Phone No.: (210) 233-3020	Extension:
6. Fax No.: (210) 233-5468	E-mail Address:

7. Indicate the type of Customer:

- | | | |
|---|---|--|
| <input type="checkbox"/> Individual | <input type="checkbox"/> Sole Proprietorship-D.B.A. | <input type="checkbox"/> Limited Partnership |
| <input type="checkbox"/> Corporation | <input type="checkbox"/> Federal Government | <input type="checkbox"/> General Partnership |
| <input type="checkbox"/> State Government | <input type="checkbox"/> County Government | <input type="checkbox"/> City Government |
| <input type="checkbox"/> Other Government | <input checked="" type="checkbox"/> Other (describe): Public Utility | |

8. Independent Operator: <input type="checkbox"/> Yes <input checked="" type="checkbox"/> No (If governmental entity, subsidiary, or part of a larger corporation, check "No".)	
9. Number of Employees: <input type="checkbox"/> 0-20; <input type="checkbox"/> 21-100; <input type="checkbox"/> 101-250; <input type="checkbox"/> 251-500; or <input checked="" type="checkbox"/> 501 or higher	
10. Customer Business Tax and Filing Numbers <i>(This item is not applicable to Individuals, Government, GP or Sole Proprietor.)</i> REQUIRED for Corporations and Limited Partnerships (Verify the entity's status and filing no. with TX SOS at 512/463-5555)	
State Franchise Tax ID Number:	Federal Tax ID:
TX SOS Charter (filing) Number:	DUNS Number (if known):
B. APPLICATION CONTACT	
If TCEQ needs additional information regarding this application, who should be contacted?	
1. Name: <i>Patrick O'Connor</i>	Title: <i>Project Manager</i> Company: <i>San Antonio Water System</i>
2. Phone No.: (<i>210</i>) <i>233-3020</i>	Extension:
3. Fax No.: (<i>210</i>) <i>233-5468</i>	E-mail Address: <i>poconnor@saws.org</i>
C. REGULATED ENTITY (RE) INFORMATION ON PROJECT OR SITE	
1. TCEQ Issued RE Reference Number (RN): RN (Search Central Registry)	
2. Name of Project or Site (the name as known by the community where this facility/project is located): <i>Medina River Sewer Outfall: Segment 4 (SAWS Job No. 12-2504)</i> (example: phase and name of subdivision or name of project that's unique to the site)	
3. Does the site have a physical address? If Yes, complete Section A for a physical address. If No, complete Section B for site location information.	
Section A: Enter the physical address for the site. (verify it with USPS.com or other delivery source)	
Street Number:	Street Name:
City:	ZIP Code:
Section B: Enter the site location information.	
If no physical address (Street Number & Street Name), provide a written location access description to the site: (Ex.: phase 1 of Woodland subdivision located 2 miles west from intersection of Hwy 290 & IH35 accessible on Hwy 290 South) <i>From approximately 240 feet west of Somerset Road to approximately 100 feet west of Pearsall Road</i>	
City where the site is located or nearest city to site: <i>San Antonio</i>	ZIP Code where site is located: <i>78073</i>
4. Identify the county where the site is located: <i>Bexar</i>	
5. Latitude: <i>N 29°17'39.2"</i>	Longitude: <i>W 98°36'32.4"</i>
6. What is the primary business of this entity? In your own words, briefly describe the primary business of the Regulated Entity: (Do not repeat the SIC and NAICS code) <i>Construction of a sanitary sewer main</i>	
7. What is the mailing address for the regulated entity?	
Is the RE mailing address the same as the Operator? <input checked="" type="checkbox"/> Yes, address is the same as Operator <input type="checkbox"/> No, provide the address	
Street Number:	Street Name:
City:	State: ZIP Code:
D. GENERAL CHARACTERISTICS	
1. Is the site located on Indian Country Lands? <input checked="" type="checkbox"/> No <input type="checkbox"/> Yes – If Yes, do not submit this NOI. Contact EPA, Region VI If the site is on Indian country lands, you must obtain authorization through EPA, Region VI.	
2. What is the Standard Industrial Classification (SIC) code (see instructions for common codes): (Search Osha.gov) Primary: <u><i>1623</i></u> Secondary: _____	

3(a) What is the total number of acres disturbed? 81

3(b) Is the project site part of a larger common plan of development or sale? Yes No
 If Yes, the total number of acres disturbed can be less than 5 acres.
 If No, the total number of acres disturbed must be 5 or more. If the total number of acres disturbed is less than 5 then the project site does not qualify for coverage through this Notice of Intent. Coverage will be denied. See the requirements in the general permit for small construction sites.

4. Discharge Information (all information MUST be provided or the permit will be denied)

4(a) What is the name of the water body(s) to receive the storm water runoff or potential runoff from the site?
Medina River

4(b) What is the segment number(s) of the classified water body(s) that the discharge or potential discharge will eventually reach? 1903

4(c) Are any of the surface water bodies receiving discharges from the construction site on the latest EPA-approved CWA 303(d) list of impaired waters?
 Yes No
 If Yes, provide the name of the impaired water body(s). _____

4(d) Is the discharge into an MS4? Yes No
 If Yes, what is the name of the MS4 Operator? SAWS
 Note: The general permit requires you to send a copy of the NOI to the MS4 Operator.

4(e) Is the discharge or potential discharge within the Recharge Zone, Contributing Zone, or Contributing Zone within the Transition Zone of the Edwards Aquifer?
 Yes No
 If the answer is Yes, please note that a copy of the agency approved Plan required by the Edwards Aquifer Rule (30 TAC Chapter 213) must be included or referenced in the Storm Water Pollution Prevention Plan.

E. CERTIFICATION

Check "Yes" to the certifications below. Failure to certify to all items will result in denial.

<input type="checkbox"/> Yes	I certify that I have obtained a copy and understand the terms and conditions of the general permit (TXR150000).
<input type="checkbox"/> Yes	I certify that the full legal name of the entity (Operator) applying for this permit has been provided and is legally authorized to do business in Texas.
<input type="checkbox"/> Yes	I understand that a Notice of Termination (NOT) must be submitted when this authorization is no longer needed.
<input type="checkbox"/> Yes	I certify that a storm water pollution prevention plan has been developed and implemented prior to construction, and that is compliant with any applicable local sediment and erosion control plans and prepared and implemented as required in the general permit TXR150000.

Operator Certification:

I, _____
 Typed or printed name (Required & must be legible) Title (Required & legible)

certify under penalty of law that this document and all attachments were prepared under my direction or supervision in accordance with a system designed to assure that qualified personnel properly gather and evaluate the information submitted. Based on my inquiry of the person or persons who manage the system, or those persons directly responsible for gathering the information, the information submitted is, to the best of my knowledge and belief, true, accurate, and complete. I am aware there are significant penalties for submitting false information, including the possibility of fine and imprisonment for knowing violations.

I further certify that I am authorized under 30 Texas Administrative Code §305.44 to sign and submit this document, and can provide documentation in proof of such authorization upon request.

Signature: _____ Date: _____
 (Use blue ink)

**Texas Commission on Environmental Quality
General Permit Payment Submittal Form
\$325 for a paper Construction NOI Application Fee**

Use this form to submit your Application Fee only if you are mailing your payment.

- Complete items 1 through 5 below:
- Staple your check in the space provided at the bottom of this document.
- Do not mail this form with your NOI form.
- Do not mail this form to the same address as your NOI.

Mail this form and your check to:

BY REGULAR U.S. MAIL

Texas Commission on Environmental Quality
Financial Administration Division
Cashier's Office, MC-214
P.O. Box 13088
Austin, TX 78711-3088

BY OVERNIGHT/EXPRESS MAIL

Texas Commission on Environmental Quality
Financial Administration Division
Cashier's Office, MC-214
12100 Park 35 Circle
Austin, TX 78753

Fee Code: **GPA** General Permit: **TXR150000**

1. Check / Money Order No:

2. Amount of Check/Money Order:

3. Date of Check or Money Order:

4. Name on Check or Money Order:

5. NOI INFORMATION

If the check is for more than one NOI, list each Project/Site (RE) Name and Physical Address exactly as provided on the NOI. **DO NOT SUBMIT A COPY OF THE NOI WITH THIS FORM AS IT COULD CAUSE DUPLICATE PERMIT ENTRIES.**

See Attached List of Sites (If more space is needed, you may attach a list.)

Project/Site (RE) Name:

Medina River Sewer Outfall: Segment 4 (SAWS Job No. 12-2504)

Project/Site (RE) Physical Address:

*From approximately 240 feet west of Somerset Road to approximately 100 feet west of Pearsall Road
San Antonio, TX 78073*

Staple Check In This Space

Did you complete everything? Use this checklist to be sure!

Are you ready to mail your form to TCEQ? Go to the General Information Section of the Instructions for mailing addresses.

Customer GP Notice of Intent Checklist TXR150000	
√	This checklist is for use by the operator to ensure a complete application. Missing information may result in denial of coverage under the permit. (See NOI Process description in the Instructions)
<input type="checkbox"/>	Application Fee of \$325.00 was mailed separately to TCEQ's Cashiers's Office (separate from the NOI) or the EPA PAY payment voucher is attached.
√	OPERATOR INFORMATION - Confirm each item is complete: √ <input checked="" type="checkbox"/> Customer Number (CN) issued by TCEQ Central Registry <input checked="" type="checkbox"/> Legal Name as filed to do business in Texas (Call TX SOS 512/463-5555) <input type="checkbox"/> Name and Title of person signing the application. This person must meet signatory requirements in 30 TAC Section 305.43 <input checked="" type="checkbox"/> Operator Mailing Address is complete & verifiable with USPS. www.usps.com <input checked="" type="checkbox"/> Phone Numbers/E-mail Address <input checked="" type="checkbox"/> Type of Operator (Entity Type) <input checked="" type="checkbox"/> Independent Operator <input checked="" type="checkbox"/> Number of Employees <input checked="" type="checkbox"/> For Corporations or Limited Partnerships – Tax ID and SOS Filing numbers are REQUIRED
√	Application Contact person we can call for questions about this application.
√	REGULATED ENTITY (RE) INFORMATION ON PROJECT OR SITE - Confirm each item is complete: √ <input type="checkbox"/> Regulated Entity Reference Number (RN) (if site is already regulated by TCEQ) <input checked="" type="checkbox"/> Site/Project Name/Regulated Entity <input checked="" type="checkbox"/> Site/Project (RE) Physical Address Please do not use a rural route or post office box for a site location <input checked="" type="checkbox"/> Or if no physical address, the location information that includes description, zip code and city is listed. <input checked="" type="checkbox"/> Latitude and Longitude TCEQ USGS Topographic Map Viewer or TerraServer-USA <input checked="" type="checkbox"/> Business description <input checked="" type="checkbox"/> Site Mailing Address (checked same as operator or complete & verifiable with USPS. www.usps.com)
√	GENERAL CHARACTERISTICS - Confirm each item is complete: √ <input checked="" type="checkbox"/> Indian Country Lands –the facility is not on Indian Country Lands <input checked="" type="checkbox"/> Standard Industrial Classification (SIC) code www.osha.gov/oshstats/sicser.html <input checked="" type="checkbox"/> Acres Disturbed is provided and qualifies for coverage through a NOI. <input checked="" type="checkbox"/> Common plan of development or for sale? <input checked="" type="checkbox"/> Discharge Information: <input checked="" type="checkbox"/> receiving water body <input checked="" type="checkbox"/> segment number(s) is REQUIRED <input checked="" type="checkbox"/> water body on the latest EPA-Approved Clean Water Act 303(d) list of impaired waters <input checked="" type="checkbox"/> MS4 Operator <input checked="" type="checkbox"/> Edwards Aquifer Rule
<input type="checkbox"/>	CERTIFICATION Certification statements have been checked indicating "Yes" Signature meets 30 Texas Administrative Code (TAC) §305.44 and is original and has been provided for the Operator.



Notice of Intent (NOI) for Storm Water Discharges Associated with Construction Activity under TPDES General Permit (TXR150000)

TCEQ Office Use Only
 Permit No.: TXR15
 RN:
 CN:
 Ref No:



Sign up now for ePermits NOI at www6.tceq.state.tx.us/steers
 Get Instant Permit Coverage and only pay a \$225 application fee.

If filing a paper NOI you can pay the application fee on line? Go to www.tceq.state.tx.us/epay
 Select Fee Type: GENERAL PERMIT CONSTRUCTION STORM WATER DISCHARGE NOI APPLICATION
 If submitting a paper NOI, coverage under the general permit starts seven (7) days after the date postmarked for delivery to TCEQ.

IMPORTANT:

- Use the **INSTRUCTIONS** to fill out each question in this form.
- Use the attached **CUSTOMER CHECKLIST** to make certain all you filled out all required information.
- Incomplete applications **WILL** delay approval or result in **automatic Denial**.

Renewal of General Permit

Is this NOI to renew an ACTIVE permit?

- Yes - What is your permit number? Permit No. TXR15 _____
 No - a permit number will be issued.

Application Fee if mailing a paper NOI:

You must pay the \$325 Application Fee to TCEQ for the application to be considered complete. Payment and NOI must be mailed to separate addresses. See instructions for correct mailing addresses.

Provide your payment information below, for us to verify payment of the application fee:

<input type="checkbox"/> Mailed:	Check/Money Order No.:	Company Name on checking account:
<input type="checkbox"/> EPAY:	Voucher No.:	Is the Payment Voucher copy attached? <input type="checkbox"/> Yes

A. OPERATOR (applicant)

1. If the applicant is currently a customer with TCEQ, what is the Customer Number (CN) issued to this entity?
 CN _____ (Search Central Registry)
2. What is the Legal Name of the entity (applicant) applying for this permit?

(The legal name must be spelled exactly as filed with the Texas Secretary of State, County, or in the legal document forming the entity.)

3. What is the name and title of the person signing the application?

(The person must be an official meeting signatory requirements in TAC 305.43(a).)

Name:	Job Title:
-------	------------

4. What is the Operator's (applicant) mailing address as recognized by the **US Postal Service?** (verify at USPS.com)

Address:	Suite No./Bldg. No./Mail Code:	
City:	State:	ZIP Code:
Country Mailing Information (if outside USA):	Country Code:	Postal Code:

5. Phone No.: () Extension:
6. Fax No.: () E-mail Address:

7. Indicate the type of Customer:

- | | | |
|---|---|--|
| <input type="checkbox"/> Individual | <input type="checkbox"/> Sole Proprietorship-D.B.A. | <input type="checkbox"/> Limited Partnership |
| <input type="checkbox"/> Corporation | <input type="checkbox"/> Federal Government | <input type="checkbox"/> General Partnership |
| <input type="checkbox"/> State Government | <input type="checkbox"/> County Government | <input type="checkbox"/> City Government |
| <input type="checkbox"/> Other Government | <input type="checkbox"/> Other (describe): | |

8. Independent Operator: <input type="checkbox"/> Yes <input type="checkbox"/> No (If governmental entity, subsidiary, or part of a larger corporation, check "No".)	
9. Number of Employees: <input type="checkbox"/> 0-20; <input type="checkbox"/> 21-100; <input type="checkbox"/> 101-250; <input type="checkbox"/> 251-500; or <input type="checkbox"/> 501 or higher	
10. Customer Business Tax and Filing Numbers <i>(This item is not applicable to Individuals, Government, GP or Sole Proprietor.)</i> REQUIRED for Corporations and Limited Partnerships (Verify the entity's status and filing no. with TX SOS at 512/463-5555)	
State Franchise Tax ID Number:	Federal Tax ID:
TX SOS Charter (filing) Number:	DUNS Number (if known):
B. APPLICATION CONTACT	
If TCEQ needs additional information regarding this application, who should be contacted?	
1. Name:	Title: Company:
2. Phone No.: ()	Extension:
3. Fax No.:	E-mail Address:
C. REGULATED ENTITY (RE) INFORMATION ON PROJECT OR SITE	
1. TCEQ Issued RE Reference Number (RN): RN (Search <u>Central Registry</u>)	
2. Name of Project or Site (the name as known by the community where this facility/project is located): Medina River Sewer Outfall: Segment 4 (SAWS Job No. 12-2504) (example: phase and name of subdivision or name of project that's unique to the site)	
3. Does the site have a physical address? If Yes , complete Section A for a physical address. If No , complete Section B for site location information.	
Section A: Enter the physical address for the site. (verify it with <u>USPS.com</u> or other delivery source)	
Street Number:	Street Name:
City:	ZIP Code:
Section B: Enter the site location information.	
If no physical address (Street Number & Street Name), provide a written location access description to the site: (Ex.: phase 1 of Woodland subdivision located 2 miles west from intersection of Hwy 290 & IH35 accessible on Hwy 290 South) From approximately 240 feet west of Somerset Road to approximately 100 feet west of Pearsall Road	
City where the site is located or nearest city to site: San Antonio	ZIP Code where site is located: 78073
4. Identify the county where the site is located: Bexar	
5. Latitude: N 29°17'39.2"	Longitude: W 98°36'32.4"
6. What is the primary business of this entity? In your own words, briefly describe the primary business of the Regulated Entity: (Do not repeat the SIC and NAICS code) Construction of a sanitary sewer main	
7. What is the mailing address for the regulated entity?	
Is the RE mailing address the same as the Operator? <input type="checkbox"/> Yes, address is the same as Operator <input type="checkbox"/> No, provide the address	
Street Number:	Street Name:
City:	State: ZIP Code:
D. GENERAL CHARACTERISTICS	
1. Is the site located on Indian Country Lands? <input checked="" type="checkbox"/> No <input type="checkbox"/> Yes – If Yes, do not submit this NOI. Contact EPA, Region VI If the site is on Indian country lands, you must obtain authorization through EPA, Region VI.	
2. What is the Standard Industrial Classification (SIC) code (see instructions for common codes): (Search <u>Osha.gov</u>) Primary: 1623 Secondary: _____	

3(a) What is the total number of acres disturbed? 81

3(b) Is the project site part of a larger common plan of development or sale? Yes No

If Yes, the total number of acres disturbed can be less than 5 acres.

If No, the total number of acres disturbed must be 5 or more. If the total number of acres disturbed is less than 5 then the project site does not qualify for coverage through this Notice of Intent. Coverage will be denied. See the requirements in the general permit for small construction sites.

4. Discharge Information (all information MUST be provided or the permit will be denied)

4(a) What is the name of the water body(s) to receive the storm water runoff or potential runoff from the site?
Medina River

4(b) What is the segment number(s) of the classified water body(s) that the discharge or potential discharge will eventually reach? 1903

4(c) Are any of the surface water bodies receiving discharges from the construction site on the latest EPA-approved CWA 303(d) list of impaired waters?

Yes No

If Yes, provide the name of the impaired water body(s). _____

4(d) Is the discharge into an MS4? Yes No

If Yes, what is the name of the MS4 Operator? SAWS

Note: The general permit requires you to send a copy of the NOI to the MS4 Operator.

4(e) Is the discharge or potential discharge within the Recharge Zone, Contributing Zone, or Contributing Zone within the Transition Zone of the Edwards Aquifer?

Yes No

If the answer is Yes, please note that a copy of the agency approved Plan required by the Edwards Aquifer Rule (30 TAC Chapter 213) must be included or referenced in the Storm Water Pollution Prevention Plan.

E. CERTIFICATION

Check "Yes" to the certifications below. Failure to certify to all items will result in denial.

Yes I certify that I have obtained a copy and understand the terms and conditions of the general permit (TXR150000).

Yes I certify that the full legal name of the entity (Operator) applying for this permit has been provided and is legally authorized to do business in Texas.

Yes I understand that a Notice of Termination (NOT) must be submitted when this authorization is no longer needed.

Yes I certify that a storm water pollution prevention plan has been developed and implemented prior to construction, and that is compliant with any applicable local sediment and erosion control plans and prepared and implemented as required in the general permit TXR150000.

Operator Certification:

I, _____
Typed or printed name (Required & must be legible) Title (Required & legible)

certify under penalty of law that this document and all attachments were prepared under my direction or supervision in accordance with a system designed to assure that qualified personnel properly gather and evaluate the information submitted. Based on my inquiry of the person or persons who manage the system, or those persons directly responsible for gathering the information, the information submitted is, to the best of my knowledge and belief, true, accurate, and complete. I am aware there are significant penalties for submitting false information, including the possibility of fine and imprisonment for knowing violations.

I further certify that I am authorized under 30 Texas Administrative Code §305.44 to sign and submit this document, and can provide documentation in proof of such authorization upon request.

Signature: _____
(Use blue ink)

Date: _____

**Texas Commission on Environmental Quality
General Permit Payment Submittal Form
\$325 for a paper Construction NOI Application Fee**

Use this form to submit your Application Fee only if you are mailing your payment.

- Complete items 1 through 5 below:
- Staple your check in the space provided at the bottom of this document.
- Do not mail this form with your NOI form.
- Do not mail this form to the same address as your NOI.

Mail this form and your check to:

BY REGULAR U.S. MAIL

Texas Commission on Environmental Quality
Financial Administration Division
Cashier's Office, MC-214
P.O. Box 13088
Austin, TX 78711-3088

BY OVERNIGHT/EXPRESS MAIL

Texas Commission on Environmental Quality
Financial Administration Division
Cashier's Office, MC-214
12100 Park 35 Circle
Austin, TX 78753

Fee Code: **GPA**

General Permit: TXR150000

1. Check / Money Order No:

2. Amount of Check/Money Order:

3. Date of Check or Money Order:

4. Name on Check or Money Order:

5. NOI INFORMATION

If the check is for more than one NOI, list each Project/Site (RE) Name and Physical Address exactly as provided on the NOI. **DO NOT SUBMIT A COPY OF THE NOI WITH THIS FORM AS IT COULD CAUSE DUPLICATE PERMIT ENTRIES.**

See Attached List of Sites (If more space is needed, you may attach a list.)

Project/Site (RE) Name:

Medina River Sewer Outfall: Segment 4 (SAWS Job No. 12-2504)

Project/Site (RE) Physical Address:

*From approximately 240 feet west of Somerset Road to approximately 100 feet west of Pearsall Road
San Antonio, Texas 78073*

Staple Check In This Space

Did you complete everything? Use this checklist to be sure!

Are you ready to mail your form to TCEQ? Go to the General Information Section of the Instructions for mailing addresses.

Customer GP Notice of Intent Checklist TXR150000	
√	This checklist is for use by the operator to ensure a complete application. Missing information may result in denial of coverage under the permit. (See NOI Process description in the Instructions)
<input type="checkbox"/>	Application Fee of \$325.00 was mailed separately to TCEQ's Cashiers's Office (separate from the NOI) or the EPAY payment voucher is attached.
<input type="checkbox"/>	OPERATOR INFORMATION - Confirm each item is complete: √ <input type="checkbox"/> Customer Number (CN) issued by TCEQ Central Registry <input type="checkbox"/> Legal Name as filed to do business in Texas (Call TX SOS 512/463-5555) <input type="checkbox"/> Name and Title of person signing the application. This person must meet signatory requirements in 30 TAC Section 305.43 <input type="checkbox"/> Operator Mailing Address is complete & verifiable with USPS. www.usps.com <input type="checkbox"/> Phone Numbers/E-mail Address <input type="checkbox"/> Type of Operator (Entity Type) <input type="checkbox"/> Independent Operator <input type="checkbox"/> Number of Employees <input type="checkbox"/> For Corporations or Limited Partnerships – Tax ID and SOS Filing numbers are REQUIRED
<input type="checkbox"/>	Application Contact person we can call for questions about this application.
<input type="checkbox"/>	REGULATED ENTITY (RE) INFORMATION ON PROJECT OR SITE - Confirm each item is complete: √ <input type="checkbox"/> Regulated Entity Reference Number (RN) (if site is already regulated by TCEQ) <input checked="" type="checkbox"/> Site/Project Name/Regulated Entity <input checked="" type="checkbox"/> Site/Project (RE) Physical Address Please do not use a rural route or post office box for a site location <input checked="" type="checkbox"/> Or if no physical address, the location information that includes description, zip code and city is listed. <input checked="" type="checkbox"/> Latitude and Longitude TCEQ USGS Topographic Map Viewer or TerraServer-USA <input checked="" type="checkbox"/> Business description <input type="checkbox"/> Site Mailing Address (checked same as operator or complete & verifiable with USPS. www.usps.com)
<input type="checkbox"/>	GENERAL CHARACTERISTICS - Confirm each item is complete: √ <input checked="" type="checkbox"/> Indian Country Lands –the facility is not on Indian Country Lands <input checked="" type="checkbox"/> Standard Industrial Classification (SIC) code www.osha.gov/oshstats/sicser.html <input checked="" type="checkbox"/> Acres Disturbed is provided and qualifies for coverage through a NOI. <input checked="" type="checkbox"/> Common plan of development or for sale? <input checked="" type="checkbox"/> Discharge Information: <input checked="" type="checkbox"/> receiving water body <input checked="" type="checkbox"/> segment number(s) is REQUIRED <input checked="" type="checkbox"/> water body on the latest EPA-Approved Clean Water Act 303(d) list of impaired waters <input checked="" type="checkbox"/> MS4 Operator <input checked="" type="checkbox"/> Edwards Aquifer Rule
<input type="checkbox"/>	CERTIFICATION Certification statements have been checked indicating "Yes" Signature meets 30 Texas Administrative Code (TAC) §305.44 and is original and has been provided for the Operator.

Notice of Intent (NOI) for Storm Water Discharges Associated with Construction Activity under TPDES General Permit (TXR150000)

General Information and Instructions

GENERAL INFORMATION

Where to Send the Notice of Intent (NOI) and other related forms:

BY REGULAR U.S. MAIL

Texas Commission on Environmental Quality
Storm Water Processing Center (MC228)
P.O. Box 13087
Austin, TX 78711-3087

BY OVERNIGHT/EXPRESS MAIL

Texas Commission on Environmental Quality
Storm Water Processing Center (MC228)
12100 Park 35 Circle
Austin, TX 78753

TCEQ Contact list:

Application Processing Questions relating to the status and form requirements:	512/239-3700, 512/245-0130 or swpermit@tceq.state.tx.us
Technical Questions relating to the general permit:	512/239-4671 or swgp@tceq.state.tx.us
Environmental Law Division:	512/239-0600
Records Management for obtaining copies of forms submitted to TCEQ:	512/239-0900
Information Services for obtaining reports from program data bases (as available):	512/239-DATA (3282)
Financial Administration's Cashier's office:	512/239-0357 or 512/239-0187

Notice of Intent Process:

When your NOI is received by the program, the form will be processed as follows:

- 1. Administrative Review:** Each item on the form will be reviewed for a complete response. In addition, the operator's legal name must be verified with Texas Secretary of State as valid and active (if applicable). The address(s) on the form must be verified with the US Postal service as an address receiving regular mail delivery. Never give an overnight/express mailing address.
- 2. Notice of Deficiency:** If an item is incomplete or not verifiable as indicated above, a notice of deficiency (NOD) will be mailed to the operator. The operator will have 30 days to respond to the NOD. The response will be reviewed for completeness.
- 3. Acknowledgment of Coverage:** An Acknowledgment Certificate will be mailed to the operator. This certificate acknowledges coverage under the general permit.

-or-

Denial of Coverage: If the application is too incomplete to process, or the operator fails to respond to the NOD or the response is inadequate, coverage under the general permit may be denied. If coverage is denied, the operator will be notified.

General Permit (Your Permit)

If filing the NOI through ePermits online application, coverage under the general permit begins the day the NOI is submitted to TCEQ through ePermits. **Sign up now for on line NOI at <https://www6.tceq.state.tx.us/steers/>**

If mailing a paper NOI, coverage under the general permit begins **seven (7) days after a completed NOI is postmarked for delivery to the TCEQ.** You should have a copy of your general permit when submitting your application.

You may view and print your permit for which you are seeking coverage, on the TCEQ web site http://www.tceq.state.tx.us/permitting/water_quality/stormwater/TXR15_AIR.html.

General Permit Forms

The Notice of Intent (NOI), Notice of Termination (NOT), and Notice of Change (NOC) #20391 with instructions are available in Adobe Acrobat PDF format on the TCEQ web site http://www.tceq.state.tx.us/permitting/water_quality/stormwater/TXR15_AIR.html.
Sign up now for on line Notice of Termination application at <https://www6.tceq.state.tx.us/steers/>

Change in Operator

An authorization under the general permit is not transferable. If the operator or owner of the regulated entity changes, the present permittee must submit a Notice of Termination and the new operator must submit a Notice of Intent. The NOT and NOI must be submitted not later than 10 days prior to the change in Operator status.

TCEQ Central Registry Core Data Form

The Core Data Form has been incorporated into this form. **Do not send a core data form to TCEQ.**

After final acknowledgment of coverage under the general permit, the program will assign a Customer Number (CN) and Regulated Entity Number (RN). For Construction Permits, a new RN will be assigned for each Notice of Intent filed with TCEQ, since construction project sites can overlap with other Customers. The RN assigned to your construction project will not be assigned to any other TCEQ authorization.

You can find the information on the Central Registry web site at www4.tceq.state.tx.us/crpub. You can search by the Regulated Entity (RN), Customer Number (CN) or Name (Permittee), or by your permit number under the search field labeled "Additional ID". Capitalize all letters in the permit number.

The Customer (Permittee) is responsible for providing consistent information to the TCEQ, and for updating all CN and RN data for all authorizations as changes occur. For General Permits, a Notice of Change form must be submitted to the program area.

Application Fees:

\$225.00 application fee if submitting the NOI through ePermits.

\$325.00 application fee if submitting a paper NOI for processing.

The application fee is required to be paid at the time the NOI is submitted. Failure to submit payment at the time the application is filed will cause delays in acknowledgment or denial of coverage under the general permit.

• Mailed Payments:

DO NOT mail your check with the original Notice of Intent application.

Use the attached Application Fee payment submittal form if mailing the payment. Do not include a copy of the NOI.

BY REGULAR U.S. MAIL

Texas Commission on Environmental Quality

Financial Administration Division

Cashier's Office, MC-214

P.O. Box 13088

Austin, TX 78711-3088

BY OVERNIGHT/EXPRESS MAIL

Texas Commission on Environmental Quality

Financial Administration Division

Cashier's Office, MC-214

12100 Park 35 Circle

Austin, TX 78753

• ePAY Electronic Payment:

Go to www.tceq.state.tx.us/epay

Select Water Quality, then select the fee category "GENERAL PERMIT CONSTRUCTION STORM WATER DISCHARGE NOI APPLICATION".

You must include a copy of the payment voucher with your NOI. Your NOI will not be considered complete without the payment voucher.

The Annual Water Quality Fee has been consolidated into the Application Fee effective March 5, 2008. An annual fee will not be assessed and billed to operators on 9/1/2008. This does not relieve the operator of fees due for prior fiscal year assessments.

The operator will continue to receive an invoice for payment of any past due annual fee. A 5% penalty will be assessed if the payment is received by TCEQ after the due date. Annual fee assessments cannot be waived as long as the authorization under the general permit was active on September 1 of the FY billed.

INSTRUCTIONS FOR FILLING OUT THE NOI FORM

A. OPERATOR (As defined in the general permit.)

1. TCEQ Issued Customer Number (CN)

TCEQ's Central Registry will assign each customer a number that begins with "CN," followed by nine digits. **This is not a permit number**, registration number, or license number.

- If this customer has not been assigned a Customer Reference Number, leave the space for the Customer Reference Number blank.
- If this customer has already been assigned this number, enter the operator's Customer Reference Number in the space provided.

2. Legal Name

Provide the legal name of the facility operator, as authorized to do business in Texas. The name must be provided exactly as filed with the Texas Secretary of State (SOS), or on other legal documents forming the entity, that is filed in the county where doing business. You may contact the SOS at 512/463-5555, or go to <http://www.sos.state.tx.us/corp/contact.shtml> for more information related to filing in Texas. If filed in the county where doing business, provide a copy of the legal documents showing the legal name.

3. Name and Title of person signing the Notice of Intent application form. Signature meets 30 Texas Administrative Code (TAC) §305.44

4. Operator Mailing Address

Provide a complete mailing address for receiving mail from the TCEQ. The address must be verifiable with the US Postal Service at www.usps.com, for regular mail delivery (not overnight express mail). If you find that the address is not verifiable using the USPS web search, please indicate the address is used by the USPS for regular mail delivery.

5. Phone Number

This number should correspond to this customer's mailing address given earlier. Enter the area code and phone number here. Leave "Extension" blank if this customer's phone system lacks this feature.

6. Fax Number and E-mail Address

This number and E-mail address should correspond to operator's mailing address provided earlier. (Optional Information)

7. Type of Entity

Check only one box that identifies the type of entity. Use the descriptions below to identify the appropriate entity type:

Individual is a customer who has not established a business, but conducts an activity that needs to be regulated by the TCEQ.

Sole Proprietorship— D.B.A. is a customer that is owned by only one person and has not been incorporated. This business may:

- be under the person's name
- have its own name ("doing business as," or d.b.a.)
- have any number of employees

Partnership is a customer that is established as a partnership as defined by the Texas Secretary of State's Office.

Corporation the customer meets all of these conditions:

- is a legally incorporated entity under the laws of any state or country
- is recognized as a corporation by the Texas Secretary of State
- has proper operating authority to operate in Texas.

Government- Federal, state, county, or city government (as appropriate)

the customer is either an agency of one of these levels of government or the governmental body itself.

Other is Estate, Trust, etc.

the customer does not fit one of the above descriptions. Enter a short description of the type of customer in the blank provided.

8. Independent Operator

Check "No" if this customer is a subsidiary, part of a larger company, or is a governmental entity. Otherwise, check "Yes."

9. Number of Employees

Check one box to show the number of employees for this customer's entire company, at all locations. This is not necessarily the number of employees at the site named in the NOI.

10. State Franchise Tax ID Number

Corporations and limited liability companies that operate in Texas are issued a franchise tax identification number. If this customer is a corporation or limited liability company, enter this number here.

Federal Tax ID

All businesses, except for some small sole proprietors, individuals, or general partnerships should have a federal taxpayer identification number (TIN).

Enter this number here. Use no prefixes, dashes, or hyphens. Sole proprietors, individuals, or general partnerships do not need to provide a federal tax ID.

TX SOS Charter (filing) Number

Corporations and Limited Partnerships required to register with the Texas Secretary of State are issued a charter or filing number. You may obtain further information by calling SOS at 512/463-5555 <http://www.sos.state.tx.us/corp/contact.shtml>.

DUNS Number Most businesses have a DUNS (Data Universal Numbering System) number issued by Dun and Bradstreet Corp. If this customer has one, enter it here.
B. Application Contact Provide the name, title and communication information of the person that TCEQ can contact for additional information regarding this application. If the application is missing information and there is no contact person to call, the application may be denied.
C. REGULATED ENTITY (RE) INFORMATION ON PROJECT OR SITE
1. <u>Regulated Entity Reference Number (RN)</u> This is a number issued by TCEQ's Central Registry to sites (a location where a regulated activity occurs) regulated by TCEQ. This is not a permit number, registration number, or license number. <ul style="list-style-type: none"> • If this Regulated Entity has not been assigned a Regulated Entity Number, leave this space blank. • If this customer has been assigned this number, enter the operator's Regulated Entity Number.
2. <u>Site/Project Name/Regulated Entity</u> If the site is already regulated by TCEQ, use the same name as on the existing <u>Regulated Entity Reference Number (RN)</u> . If new, provide the name of the site as known by the public in the area where the site is located. The name you provide on this application will be used in the TCEQ Central Registry as the Regulated Entity.
3. <u>Site/Project (RE) Physical Address</u> Section A: Enter the complete physical address of where the site is located. This must be a street number and street name for a complete physical address. This address must be validated through US Postal Service or your local police (911 service) as a valid address. Please confirm this to be a complete and valid address. In some rural areas, new addresses are being assigned to replace rural route addresses. Please do not use a rural route or post office box for a site location. Section B: If a site does not have an actual physical address that includes a street number and street name, then provide a complete written location access description, and the zip code and city where the site is located. For example: "The site is located 2 miles west from intersection of Hwy 290 & IH35, located on the southwest corner of the Hwy 290 South bound lane." This includes authorizations for construction projects such as highways and subdivision.
4. Identify the County where the site is located. If the site covers more than one county, provide the county that is most affected by the authorized activity and list the additional county(s) as secondary.
5. <u>Latitude and Longitude</u> Enter the latitude and longitude of the site in either degrees, minutes, and seconds or decimal form. For help obtaining the latitude and longitude, go to: TCEQ USGS Topographic Map Viewer or TerraServer-USA
6. <u>Description of Activity Regulated</u> In your own words, briefly describe the primary business being conducted at the site. (A description specific to what you are doing that requires this authorization - Do not repeat the SIC Code(s).)
SITE MAILING ADDRESS Provide a complete mailing address to be used by TCEQ for receiving mail at the site. In most cases, the address is the same as the operator. If so, simply place a check mark in the box. If you provide a different address, please verify the address with USPS as instructed above for the operator address.
D. GENERAL CHARACTERISTICS
1. Indian Country Lands If your site is located on Indian Country Lands, the TCEQ does not have authority to process your application. You must obtain authorization through EPA, Region VI, Dallas. Do not submit this form to TCEQ. Indian Country means (1) all land within the limits of any American Indian reservation under the jurisdiction of the U.S. government, notwithstanding the issuance of any patent, and including rights-of-way running throughout the reservation; (2) all dependent Indian communities within the borders of the United States whether within the original or subsequently acquired territory thereof, and whether within or outside the limits of a State; and (3) all Indian allotments, the Indian titles which have not been extinguished, including rights-of-way running through the same. Indian Tribe means any Indian Tribe, band, nation, or community recognized by the Secretary of the Interior and exercising substantial governmental duties and powers.
2. Standard Industrial Classification (SIC) code Provide the SIC code that best describes the construction activity being conducted at the site. Common SIC Codes related to construction activities include: 1521 Construction of Single Family Homes; 1522 Construction of Residential Bldgs. Other than Single Family Homes; 1541 Construction of Industrial Bldgs. and Warehouses; 1542 Construction of Non-residential Bldgs. other than Industrial Bldgs. and Warehouses; 1611 Highway & Street Construction, except Highway Construction; 1622 Bridge, Tunnel, & Elevated Highway Construction; 1623 Water, Sewer, Pipeline & Communications, and Power Line Construction. For help with SIC codes, go to: www.osha.gov/oshstats/sicser.html

3. Estimated Area of Land Disturbed

- 3(a). Provide the approximate number of acres that the construction site will disturb.
3(b). Indicate if the site is part of a common plan of development or for sale.

Construction activities that disturb less than one acre, unless they are part of a larger common plan that disturbs more than one acre, do not require permit coverage.

Construction activities that disturb between one and five acres, unless they are part of a common plan that disturbs five acres or more acres, do not require submission of an NOI. Therefore, the estimated area of land disturbed should not be less than five, unless the project is part of a larger common plan that disturbs five or more acres.

"Disturb" means any clearing, grading, excavating, or other similar activities. If you have any questions about this item, please call the storm water technical staff at (512)239-4671.

4. Discharge Information

4 (a). The storm water may be discharged directly to a receiving stream or through a **MS4*** from your site. It eventually reaches a receiving water body such as a local stream or lake, possibly via a drainage ditch. You must provide the name of the water body that receives the discharge from the site (a local stream or lake).

4 (b). The classified segment number(s) is **REQUIRED** to get coverage. Go to the link to find the segment number of the classified water body where storm water will flow <http://www.tceq.state.tx.us/compliance/monitoring/water/quality/data/wqm/viewer/viewer.html>. Call Water Quality Assessments at 512/239-4671 for further assistance.

4 (c). If any surface water body(s) receiving discharges from the construction site are on the latest EPA-approved CWA § 303(d) list of impaired waters, provide the name(s) of the water body(s).

EPA approved CWA 303d list of impaired waters can be found at: [Texas Water Quality Inventory and 303\(d\) List - Texas Commission on Environmental Quality - www.tceq.state.tx.us](http://www.tceq.state.tx.us/compliance/monitoring/water/quality/data/wqm/viewer/viewer.html)

4 (d). Identify the **MS4*** Operator name if the storm water discharge is into an MS4.

***MS4 is an acronym for Municipal separate storm sewer system. MS4 is defined as a separate storm sewer system owned or operated by a state, city, town, county, district, association, or other public body (created by or pursuant to state law) having jurisdiction over disposal of sewage, industrial wastes, storm water, or other wastes, including special districts under state law such as a sewer district, flood control or drainage district, or similar entity, or an Indian tribe or an authorized Indian tribal organization, that discharges to water in the state.**

For assistance, you may call the technical staff of the Water Quality Assessment & Standards Section at 512/239-4671.

4 (e). Edwards Aquifer Rule

See maps on the TCEQ website to determine if the site is located within the Recharge Zone, Contributing Zone, or Contributing Zone within the Transition Zone of the Edwards Aquifer at http://www.tceq.state.tx.us/compliance/field_ops/eapp/viewer.html.

If the discharge or potential discharge is within the Recharge Zone, Contributing Zone, or Contributing Zone within the Transition Zone of the Edwards Aquifer, a site specific authorization approved by the Executive Director under the Edwards Aquifer Protection Program (30 TAC Chapter 213) is required before construction can begin.

The general permit requires the approved Contributing Zone Plan or Water Pollution Abatement Plan to be included as a part of the Storm Water Pollution Prevention Plan. The certification must be answered "Yes" for coverage under the general permit.

E. CERTIFICATIONS

Failure to indicate "Yes" to ALL of the certification items may result in denial of coverage under the general permit.

The certification must bear an original signature of a person meeting the signatory requirements specified under 30 Texas Administrative Code §305.44

IF YOU ARE A CORPORATION:

The regulation that controls who may sign an NOI or similar form is 30 Texas Administrative Code §305.44(a)(1) (see below). According to this code provision, any corporate representative may sign an NOI or similar form so long as the authority to sign such a document has been delegated to that person in accordance with corporate procedures. By signing the NOI or similar form, you are certifying that such authority has been delegated to you. The TCEQ may request documentation evidencing such authority.

IF YOU ARE A MUNICIPALITY OR OTHER GOVERNMENT ENTITY:

The regulation that controls who may sign an NOI or similar form is 30 Texas Administrative Code §305.44(a)(3) (see below). According to this code provision, only a ranking elected official or principal executive officer may sign an NOI or similar form. Persons such as the City Mayor or County Commissioner will be considered ranking elected officials. In order to identify the principal executive officer of your government entity, it may be beneficial to consult your city charter, county or city ordinances, or the Texas statute(s) under which your government entity was formed. An NOI or

similar document that is signed by a government official who is not a ranking elected official or principal executive officer does not conform to §305.44(a)(3). The signatory requirement may not be delegated to a government representative other than those identified in the regulation. By signing the NOI or similar form, you are certifying that you are either a ranking elected official or principal executive officer as required by the administrative code. Documentation demonstrating your position as a ranking elected official or principal executive officer may be requested by the TCEQ.

If you have any questions or need additional information concerning the signatory requirements discussed above, please contact the Texas Commission on Environmental Quality's Environmental Law Division at 512/239-0600.

30 Texas Administrative Code
§305.44. Signatories to Applications.

(a) All applications shall be signed as follows.

(1) For a corporation, the application shall be signed by a responsible corporate officer. For purposes of this paragraph, a responsible corporate officer means a president, secretary, treasurer, or vice-president of the corporation in charge of a principal business function, or any other person who performs similar policy or decision-making functions for the corporation; or the manager of one or more manufacturing, production, or operating facilities employing more than 250 persons or having gross annual sales or expenditures exceeding \$25 million (in second-quarter 1980 dollars), if authority to sign documents has been assigned or delegated to the manager in accordance with corporate procedures. Corporate procedures governing authority to sign permit or post-closure order applications may provide for assignment or delegation to applicable corporate positions rather than to specific individuals.

(2) For a partnership or sole proprietorship, the application shall be signed by a general partner or the proprietor, respectively.

(3) For a municipality, state, federal, or other public agency, the application shall be signed by either a principal executive officer or a ranking elected official. For purposes of this paragraph, a principal executive officer of a federal agency includes the chief executive officer of the agency, or a senior executive officer having responsibility for the overall operations of a principal geographic unit of the agency (e.g., regional administrator of the EPA).

Texas Administrative Code

TITLE 30	ENVIRONMENTAL QUALITY
PART 1	TEXAS COMMISSION ON ENVIRONMENTAL QUALITY
CHAPTER 305	CONSOLIDATED PERMITS
SUBCHAPTER C	APPLICATION FOR PERMIT OR POST-CLOSURE ORDER
RULE §305.44	Signatories to Applications

(a) All applications shall be signed as follows.

(1) For a corporation, the application shall be signed by a responsible corporate officer. For purposes of this paragraph, a responsible corporate officer means a president, secretary, treasurer, or vice-president of the corporation in charge of a principal business function, or any other person who performs similar policy or decision-making functions for the corporation; or the manager of one or more manufacturing, production, or operating facilities employing more than 250 persons or having gross annual sales or expenditures exceeding \$25 million (in second-quarter 1980 dollars), if authority to sign documents has been assigned or delegated to the manager in accordance with corporate procedures. Corporate procedures governing authority to sign permit or post-closure order applications may provide for assignment or delegation to applicable corporate positions rather than to specific individuals.

(2) For a partnership or sole proprietorship, the application shall be signed by a general partner or the proprietor, respectively.

(3) For a municipality, state, federal, or other public agency, the application shall be signed by either a principal executive officer or a ranking elected official. For purposes of this paragraph, a principal executive officer of a federal agency includes the chief executive officer of the agency, or a senior executive officer having responsibility for the overall operations of a principal geographic unit of the agency (e.g., regional administrator of the EPA).

(b) A person signing an application shall make the following certification: "I certify under penalty of law that this document and all attachments were prepared under my direction or supervision in accordance with a system designed to assure that qualified personnel properly gather and evaluate the information submitted. Based on my inquiry of the person or persons who manage the system, or those persons directly responsible for gathering the information, the information submitted is, to the best of my knowledge and belief, true, accurate, and complete. I am aware there are significant penalties for submitting false information, including the possibility of fine and imprisonment for knowing violations."

(c) For a hazardous solid waste permit or a post-closure order, the application must be signed by the owner and operator of the facility.

(d) For radioactive material license applications under Chapter 336 of this title (relating to Radioactive Substance Rules), the applicant or person duly authorized to act for and on the applicant's behalf must sign the application.

Source Note: The provisions of this §305.44 adopted to be effective June 19, 1986, 11 TexReg 2591; amended to be effective July 14, 1987, 12 TexReg 2102; amended to be effective October 8, 1990, 15 TexReg 5492; amended to be effective June 5, 1997, 22 TexReg 4583; amended to be effective January 30, 2003, 28 TexReg 705



LARGE CONSTRUCTION SITE NOTICE

FOR THE
Texas Commission on Environmental Quality (TCEQ)
Storm Water Program
TPDES GENERAL PERMIT TXR150000
“PRIMARY OPERATOR” NOTICE

This notice applies to construction sites operating under Part II.E.3. of the TPDES General Permit Number TXR150000 for discharges of storm water runoff from construction sites equal to or greater than five acres, including the larger common plan of development. The information on this notice is required in Part III.E.2. of the general permit. This notice shall be posted along with a copy of the signed Notice of Intent (NOI), as applicable. Additional information regarding the TCEQ storm water permit program may be found on the internet at: http://www.tceq.state.tx.us/nav/permits/sw_permits.html

Site-Specific TPDES Authorization Number:	
Operator Name:	San Antonio Water System
Contact Name and Phone Number:	Patrick O'Connor (210) 233-3020
Project Description: <i>Physical address or description of the site's location, and estimated start date and projected end date, or date that disturbed soils will be stabilized.</i>	From approximately 240 feet west of Somerset Road to approximately 100 feet west of Pearsall Road Start Date: 02/20/12 Finish Date: 08/16/13
Location of Storm Water Pollution Prevention Plan:	

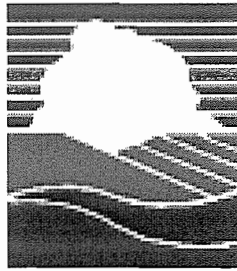

LARGE CONSTRUCTION SITE NOTICE

FOR THE
Texas Commission on Environmental Quality (TCEQ)
Storm Water Program
TPDES GENERAL PERMIT TXR150000
“PRIMARY OPERATOR” NOTICE

This notice applies to construction sites operating under Part II.E.3. of the TPDES General Permit Number TXR150000 for discharges of storm water runoff from construction sites equal to or greater than five acres, including the larger common plan of development. The information on this notice is required in Part III.E.2. of the general permit. This notice shall be posted along with a copy of the signed Notice of Intent (NOI), as applicable. Additional information regarding the TCEQ storm water permit program may be found on the internet at: http://www.tceq.state.tx.us/nav/permits/sw_permits.html

Site-Specific TPDES Authorization Number:	
Operator Name:	
Contact Name and Phone Number:	
Project Description: <i>Physical address or description of the site's location, and estimated start date and projected end date, or date that disturbed soils will be stabilized.</i>	From approximately 240 feet west of Somerset Road to approximately 100 feet west of Pearsall Road Start Date: 02/20/12 Finish Date: 08/16/13
Location of Storm Water Pollution Prevention Plan:	

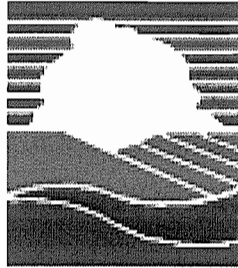

LARGE CONSTRUCTION SITE NOTICE

FOR THE
Texas Commission on Environmental Quality (TCEQ)
Storm Water Program
TPDES GENERAL PERMIT TXR150000
“SECONDARY OPERATOR” NOTICE

This notice applies to secondary operators of construction sites operating under Part II.E.3. of the TPDES General Permit Number TXR150000 for discharges of storm water runoff from construction sites equal to or greater than five acres, including the larger common plan of development. The information on this notice is required in Part III.E.2. of the general permit. Additional information regarding the TCEQ storm water permit program may be found on the internet at: http://www.tceq.state.tx.us/nav/permits/sw_permits.html

Site-Specific TPDES Authorization Number:	
Operator Name:	
Contact Name and Phone Number:	
Project Description: <i>Physical address or description of the site's location, and estimated start date and projected end date, or date that disturbed soils will be stabilized.</i>	
Location of Storm Water Pollution Prevention Plan (SWP3):	

For Large Construction Activities Authorized Under Part II.E.3. (Obtaining Authorization to Discharge) the following certification must be completed:

I _____ (Typed or Printed Name Person Completing This Certification) certify under penalty of law that I have read and understand the eligibility requirements for claiming an authorization under Part II.E.2. of TPDES General Permit TXR150000 and agree to comply with the terms of this permit. A storm water pollution prevention plan has been developed and will be implemented prior to construction, according to permit requirements. A copy of this signed notice is supplied to the operator of the MS4 if discharges enter an MS4. I am aware there are significant penalties for providing false information or for conducting unauthorized discharges, including the possibility of fine and imprisonment for knowing violations.

Signature and Title _____ Date _____

Date Notice Removed
 MS4 operator notified per Part II.F.3.

**STORMWATER QUALITY
SITE DEVELOPMENT
PERMIT APPLICATION
(Bexar County)**



BEXAR COUNTY
 INFRASTRUCTURE SERVICES DEPARTMENT
 ENVIRONMENTAL SERVICES DIVISION
 233 N. Pecos - La Trinidad, Suite 420
 San Antonio, TX 78207
 (210)335-6700 (voice)
 (210)335-6713 (fax)

SITE DEVELOPMENT PERMIT APPLICATION
STORM WATER QUALITY

Project Name: Medina River Sewer Outfall: Segment 4
 SAWS Job #12-2504

Date of Application: 10/18/11

Job Location:
 From approx. 240 ft. west of Somerset Road
 to approx. 100 ft. west of Pearsall Road

Property Owner/Developer: San Antonio Water System

Address:
 2800 U.S. Highway 281 North
 San Antonio, TX 78212

Phone: (210) 233-3020

Fax: (210) 233-5468

TCEQ Notice of Intent (NOI) Number:

Contact Name:

Contact Phone:

Contact Email:

Anticipated Work Start Date: 02/20/12

Anticipated Work Stop Date: 08/16/13

Parcel Number: N/A

Lot: N/A

Block: N/A

Subdivision: N/A

Work Description:
 Construction of 1-66", 1-24" and 1-18" sewer outfall including clearing, grubbing, trenching, tunneling or boring, sewer outfall installation, trench backfilling and project stabilization.

Submittal Requirements:

Commercial or Development over 5 Acres of Disturbance: Two (2) sets of Storm Water Management Plan (see example)

Residential or Development under 5 Acres of Disturbance: Two (2) sets of 11"x17" plans w/ narrative (must include SW3P w/ details, Drainage, and Grading) (see example)

Dewatering Plan (if applicable)

Site Development Permit Fee (\$500)

Project Type:

Single Family/Duplex/Townhouse

Manufactured Home

Multi-Family

Remodel or Addition

Commercial

Subdivision

Demolition

Other (please explain below)

Project Details:

N/A Number of Units (ex. 1,2, etc.)

N/A Number of Lots (ex. 1,2,etc.)

81+/- Acreage of Development (ex. 5 ac)

N/A Acreage of Green Spaces (ex. 1 ac)

81+/- Acreage of Total Disturbance (ex. 3 ac)

Yes Tree Survey Completed (yes or no)

Yes ESA Survey Completed (yes or no)

To remit site development fee, please make checks payable to:

BEXAR COUNTY CLERK
 233 N. Pecos - La Trinidad, Suite 420
 San Antonio, TX 78207

ADMINISTRATIVE USE ONLY:

Site Development Permit Number:

Reviewed By:

Approval:
 Accepted
 Denied

Application Date:

NOTICE:

It is the obligation of the Owner to ensure that erosion control measures SHALL be in place prior to commencement of grading, or stockpiling, and shall be maintained throughout construction as per plan. The Owner expressly grants the County a right of entry during construction to enter the site described in this application, to inspect the property, and provide direction for necessary sediment/erosion control if the permittee fails to do so. Failure to properly install sediment/erosion control will result in re-inspection and/or further penalties from County to include a \$1,000 fine or lien.

The Permittee shall:

1. Comply with Court Order on Bexar County regulations for storm water pollution prevention.
2. Install erosion and sediment control BMPs prior to beginning work on a site.
3. Notify Bexar County Stormwater Quality Program at least three (3) working days before:
 - a. Start of construction,
 - b. Completion of site clearing,
 - c. Completion of final grading,
 - d. Temporary stabilization occurs, and
 - e. Completion of final landscaping.
4. Implement the approved plans throughout the site development.
5. If BMPs need maintenance, repair, or replace; then perform task as soon as possible, but no later than ten (10) calendar days.
6. Install additional measures at the direction of the County due to changed site conditions, BMP ineffectiveness, or BMP failure.
7. After fourteen (14) days of cease of construction operations, temporary stabilization needs to be in place.
8. After twenty-one (21) days of cease of construction operations, final stabilization needs to be in place.
9. Revise the Stormwater Management Plan and site map when changes are made on-site.
10. Terminate the Site Development Permit when the site reaches permanent stabilization.
11. Remove temporary BMPs prior to the the Site Development Permit being terminated.

This permit is issued to the permittee for a specific operation and location. It cannot be reassigned, transferred, or sold to a new user, different premises or a new or changed operation by a new owner unless the new owner or designee obtains a separate Site Development Permit. Failure to obtain an approved Site Development Permit prior to beginning any construction activity or land clearing can result in a fine of up to \$1,000 per calendar day until a permit is issued.

"I certify under penalty of law that I understand the terms and conditions of the Texas Pollutant Discharge Elimination System (TPDES) General Permit for Stormwater Discharges for Construction Activities that authorizes the stormwater discharges associated to activities from the construction site identified as part of this certification. Further, by my signature, I understand that I am fully responsible, along with all other contractors and subcontractors who are performing work activities under this contract to comply with all provisions and requirements of the TPDES General Permit for Stormwater Discharges from Construction Activities and this Site Development Permit Application for Storm Water Quality."

Authorized Agent (Print Name):

Title:

Signature:

Date:

**MEDINA RIVER SEWER OUTFALL: SEGMENT 4 (SAWS JOB #12-2504)
Storm Water Pollution Prevention Plan**

NOI TRACKING FORM

Owner/Operator Name	Owner/Operator Signature	NOI Submittal Date	TCEQ Approval Date	General Permit Authorization Number

Note: Until the TCEQ responds to receipt of the NOI with a general permit authorization number, the SWP3 must specify the date that the NOI was submitted to TCEQ by each operator.

Texas Administrative Code

TITLE 30

ENVIRONMENTAL QUALITY

PART 1

TEXAS COMMISSION ON ENVIRONMENTAL QUALITY

CHAPTER 305

CONSOLIDATED PERMITS

SUBCHAPTER C

APPLICATION FOR PERMIT OR POST-CLOSURE ORDER

RULE §305.44

Signatories to Applications

(a) All applications shall be signed as follows.

(1) For a corporation, the application shall be signed by a responsible corporate officer. For purposes of this paragraph, a responsible corporate officer means a president, secretary, treasurer, or vice-president of the corporation in charge of a principal business function, or any other person who performs similar policy or decision-making functions for the corporation; or the manager of one or more manufacturing, production, or operating facilities employing more than 250 persons or having gross annual sales or expenditures exceeding \$25 million (in second-quarter 1980 dollars), if authority to sign documents has been assigned or delegated to the manager in accordance with corporate procedures. Corporate procedures governing authority to sign permit or post-closure order applications may provide for assignment or delegation to applicable corporate positions rather than to specific individuals.

(2) For a partnership or sole proprietorship, the application shall be signed by a general partner or the proprietor, respectively.

(3) For a municipality, state, federal, or other public agency, the application shall be signed by either a principal executive officer or a ranking elected official. For purposes of this paragraph, a principal executive officer of a federal agency includes the chief executive officer of the agency, or a senior executive officer having responsibility for the overall operations of a principal geographic unit of the agency (e.g., regional administrator of the EPA).

(b) A person signing an application shall make the following certification: "I certify under penalty of law that this document and all attachments were prepared under my direction or supervision in accordance with a system designed to assure that qualified personnel properly gather and evaluate the information submitted. Based on my inquiry of the person or persons who manage the system, or those persons directly responsible for gathering the information, the information submitted is, to the best of my knowledge and belief, true, accurate, and complete. I am aware there are significant penalties for submitting false information, including the possibility of fine and imprisonment for knowing violations."

(c) For a hazardous solid waste permit or a post-closure order, the application must be signed by the owner and operator of the facility.

(d) For radioactive material license applications under Chapter 336 of this title (relating to Radioactive Substance Rules), the applicant or person duly authorized to act for and on the applicant's behalf must sign the application.

Source Note: The provisions of this §305.44 adopted to be effective June 19, 1986, 11 TexReg 2591; amended to be effective July 14, 1987, 12 TexReg 2102; amended to be effective October 8, 1990, 15 TexReg 5492; amended to be effective June 5, 1997, 22 TexReg 4583; amended to be effective January 30, 2003, 28 TexReg 705

INSPECTION RECORD

MEDINA RIVER SEWER OUTFALL: SEGMENT 4 (SAWS JOB #12-2504)
Storm Water Pollution Prevention Plan

SWP3 INSPECTION FORM

Project Name: _____ **Permit No.:** _____

Address/Location: _____

Operator: _____ **Inspector:** _____

Date: _____

Administrative/Reporting	Compliant			Corrective Action No.
	Yes	No	N/A	
Is the SWP3 available on site?				
Has a copy of the NOI/NOC/CSN been submitted?				
Does the SWP3 reference other site operators?				
Does the SWP3 clearly identify each plan-sharer's responsibilities including common areas?				
Is the permit number listed for large construction sites in a shared SWP3?				
Does the SWP3 contain a copy of the Permit language?				
Are inspections being conducted?				
Do the inspection reports meet signatory requirements?				
Is the SWP3 modified based on project changes or inspection reports?				
Has the site map been updated to indicate the current location of all BMPs?				
Does the plan include a record of dates when major grading activities occur?				
Does the plan include a record of dates when construction is temporarily halted?				
Does the plan include a record of dates when stabilization measures are initiated?				
Does the plan include construction materials stored on site?				
Does the plan include waste materials stored on site?				

MEDINA RIVER SEWER OUTFALL: SEGMENT 4 (SAWS JOB #12-2504)
Storm Water Pollution Prevention Plan

Site Evaluation	Compliant			Corrective Action No.
	Yes	No	N/A	
Are the required TPDES notifications properly posted (NOI/CSN)?				
Are the areas outside the construction limits free of sediment?				
Are the areas outside of the construction limits free of waste materials / debris / litter?				
Are the adjacent streets free of off-site sediment?				
Are interior streets free of sediment?				
Are the storm drains free of sediment?				
Are outfalls or discharge points properly controlled with BMPs?				
Are the construction entrance/exit BMPs installed and functioning properly?				
Are equipment storage areas in use with appropriate BMPs?				
Is there evidence of stained soil from vehicular equipment?				
Are material storage areas in use with appropriate BMPs?				
Are fuels, lubricants, chemicals, etc. properly stored?				
Is waste collected and properly contained?				
Are disturbed soils areas properly controlled with appropriate BMPs?				
Is dust being controlled?				
Are disturbed areas appropriately stabilized?				
Are concrete truck washout pits constructed and utilized properly?				
Are portable toilets maintained properly?				
Are BMPs in use?				
Are BMPs being maintained?				
Are BMPs adequate?				
Are vegetated buffer strips functioning properly?				
Are temporary sediment control ponds in place?				
Is sediment level in ponds in compliance?				
Are drainage channels functioning property?				
Are rock berms installed and functioning properly?				
Are silt fences installed and functioning properly?				
Is inlet protection installed and functioning properly?				
Are erosion blankets installed and functioning properly?				

MEDINA RIVER SEWER OUTFALL: SEGMENT 4 (SAWS JOB #12-2504)
Storm Water Pollution Prevention Plan

Site Evaluation - continued				
	Compliant			Corrective Action No.
	Yes	No	N/A	
Are straw wattles installed and functioning properly?				
Is mulch installed and functioning properly?				
Are cutback curbs being utilized and functioning properly?				
Are other BMPs installed and functioning properly?				
Has sod or hydroseeding been installed properly?				
Is permanent or temporary vegetation established?				

_____ **A brief statement describing the qualifications of the inspector is included in this SWP3.**

"I certify under penalty of law that this document and all attachments were prepared under my direction or supervision in accordance with a system designed to assure that qualified personnel properly gather and evaluate the information submitted. Based on my inquiry of the person or persons who manage the system, or those persons directly responsible for gathering the information, the information submitted is, to the best of my knowledge and belief, true, accurate, and complete. I am aware there are significant penalties for submitting false information, including the possibility of fine and imprisonment for knowing violations."

"I further certify I am an authorized signatory in accordance with the provisions of 30 TAC §305.128."

 Inspector's Name

 Inspector's Signature

 Date

MEDINA RIVER SEWER OUTFALL: SEGMENT 4 (SAWS JOB #12-2504)
Storm Water Pollution Prevention Plan

CORRECTIVE ACTION ITEMS

Corrective Action Item #	Corrective Action	Date Noted	Date of Corrective Action	Initials

Date

Mark R. Vickery, P.G.
Texas Commission on Environmental Quality
12100 Park 35 Circle, MC 109
Austin, Texas 78753

Project Name: Medina River Sewer Outfall: Segment 4 (SAWS Job #12-2504)
TPDES Storm Water General Permit _____
Delegating an "Authorized Representative"

Dear Director:

This letter serves to designate either a person(s) or specifically described position(s) as an authorized person(s) for signing reports, storm water pollution prevention plans, certifications or other information requested by the Executive Director or required by the permit. This authorization cannot be used for signing a TPDES permit application (e.g. Notice of Intent (NOI)) in accordance with 30 TAC §305.44. The following person(s) or position(s) is hereby authorized to sign reports, plans or certifications other than NOI forms, NOT forms, NOC letters, and Construction Site Notices.

(Name or Position)

(Name or Position)

(Name or Position)

(Name or Position)

By signing this authorization, I confirm that I meet the following requirements to make such a designation as set forth in 30 TAC §305.44 as follows:

- For a corporation, the application shall be signed by a responsible corporate officer. For purposes of this paragraph, a responsible corporate officer means a president, secretary, treasurer, or vice-president of the corporation in charge of a principal business function, or any other person who performs similar policy or decision-making functions for the corporation; or the manager of one or more manufacturing, production, or operating facilities employing more than 250 persons or having gross annual sales or expenditures

exceeding \$25 million (in second-quarter 1980 dollars), if authority to sign documents has been assigned or delegated to the manager in accordance with corporate procedures. Corporate procedures governing authority to sign permit or post-closure order applications may provide for assignment or delegation to applicable corporate positions rather than to specific individuals.

- For a partnership or sole proprietorship, the application shall be signed by a general partner or the proprietor, respectively.
- For a municipality, state, federal, or other public agency, the application shall be signed by either a principal executive officer or a ranking elected official. For purposes of this paragraph, a principal executive officer of a federal agency includes the chief executive officer of the agency, or a senior executive officer having responsibility for the overall operations of a principal geographic unit of the agency (e.g., regional administrator of the EPA).

"I certify under penalty of law that this document and all attachments were prepared under my direction or supervision in accordance with a system designed to assure that qualified personnel properly gather and evaluate the information submitted. Based on my inquiry of the person or persons who manage the system, or those persons directly responsible for gathering the information, the information submitted is, to the best of my knowledge and belief, true, accurate, and complete. I am aware there are significant penalties for submitting false information, including the possibility of fine and imprisonment for knowing violations."

Name

Title

Date

Texas Administrative Code

TITLE 30	ENVIRONMENTAL QUALITY
PART 1	TEXAS COMMISSION ON ENVIRONMENTAL QUALITY
CHAPTER 305	CONSOLIDATED PERMITS
SUBCHAPTER F	PERMIT CHARACTERISTICS AND CONDITIONS
RULE §305.128	Signatories to Reports

(a) All reports requested by permits and other information requested by the executive director shall be signed by a person described in §305.44(a) of this title (relating to Signatories to Applications) or by a duly authorized representative of that person. A person is a duly authorized representative only if:

- (1) the authorization is made in writing by a person described in §305.44(a) of this title (relating to Signatories to Applications);
 - (2) the authorization specifies either an individual or a position having responsibility for the overall operation of the regulated facility or activity or for environmental matters for the applicant, such as the position of plant manager, operator of a well or well field, environmental manager, or a position of equivalent responsibility. (A duly authorized representative may thus be either a named individual or any individual occupying a named position); and
 - (3) the written authorization is submitted to the executive director.
- (b) If an authorization under this section is no longer accurate because of a change in individuals or position, a new authorization satisfying the requirements of this section must be submitted to the executive director prior to or together with any reports, information, or applications to be signed by an authorized representative.
- (c) Any person signing a report required by a permit shall make the certification set forth in §305.44(b) of this title (relating to Signatories to Applications).

Source Note: The provisions of this §305.128 adopted to be effective June 19, 1986, 11 TexReg 2597; amended to be effective July 14, 1987, 12 TexReg 2102; amended to be effective October 8, 1990, 15 TexReg 5492.

INSPECTOR'S QUALIFICATIONS

PLAN MODIFICATIONS

NOTICE OF TERMINATION



Notice of Termination (NOT)
for Authorizations under
TPDES General Permit TXR150000

TCEQ Office Use Only
Permit No.:
RN:
CN:



Sign up now for on line NOT at http://www.tceq.state.tx.us/permitting/steers/steers.html
Get your NOT Confirmation letter immediately after submitting the on line NOT form.

What is the permit number to be terminated?

Processing will be delayed without the permit number. TXR15_____

A. OPERATOR (applicant)

- 1. What is the Customer Number (CN) issued to this entity? CN_____
2. What is the full Legal Name of the current permittee?

This must be the current permittee of the permit to be terminated.

3. What is the applicant's mailing address as recognized by the US Postal Service?

Address: Suite No./Bldg. No./Mail Code:
City: State: ZIP Code:
Country Mailing Information (if outside USA). Country Code: Postal Code:
4. Phone No.: () Extension:
5. Fax No.: () E-mail Address:

B. REGULATED ENTITY (RE) INFORMATION ON PROJECT OR SITE

1. What is the TCEQ Issued RE Reference Number (RN)? RN_____

2. Name of Project or Site as currently permitted):
Medina River Sewer Outfall: Segment 4 (SAWS Job No. 12-2504)
(example: phase and name of subdivision or name of project that's unique to the site)

3. Physical Address of Project or Site as currently permitted: (enter in spaces below)

Street Number: Street Name:
City: ZIP Code: County (Counties if >1):

4. If no physical address (Street Number & Street Name), provide the written location access description to the site:
From approximately 240 feet west of Somerset Road to approximately 100 feet west of Pearsall Road

C. REASON FOR TERMINATION

Check the reason for termination:

- [] Final stabilization has been achieved on all portions of the site that are the responsibility of the Operator and all silt fences and other temporary erosion controls have either been removed, or scheduled for removal as defined in the SWP3.
[] Another permitted Operator has assumed control over all areas of the site that have not been finally stabilized, and temporary erosion controls that have been defined in the SWP3 have been transferred to the new Operator.
[] The activity is now authorized under an alternate TPDES permit.
[] The activity never began at this site that is regulated under the general permit.

D. CERTIFICATION

I, _____ Title
Typed or printed name

certify under penalty of law that this document and all attachments were prepared under my direction or supervision in accordance with a system designed to assure that qualified personnel properly gather and evaluate the information submitted. Based on my inquiry of the person or persons who manage the system, or those persons directly responsible for gathering the information, the information submitted is, to the best of my knowledge and belief, true, accurate, and complete. I am aware there are significant penalties for submitting false information, including the possibility of fine and imprisonment for knowing violations.

I further certify that I am authorized under 30 Texas Administrative Code §305.44 to sign and submit this document, and can provide documentation in proof of such authorization upon request.

Signature: _____ Date: _____
(Use blue ink)

**Notice of Termination (NOT) for Authorizations under
TPDES General Permit TXR150000
General Information and Instructions**

GENERAL INFORMATION

Where to Send the Notice of Intent (NOI):

BY REGULAR U.S. MAIL

Texas Commission on Environmental Quality
Storm Water Processing Center (MC228)
P.O. Box 13087
Austin, TX 78711-3087

BY OVERNIGHT/EXPRESS MAIL

Texas Commission on Environmental Quality
Storm Water Processing Center (MC228)
12100 Park 35 Circle
Austin, TX 78753

TCEQ Contact list:

Application Processing Questions relating to the status and form requirements:	512/239-4671
Technical Questions relating to the general permit:	512/239-4671
Environmental Law Division:	512/239-0600
Records Management for obtaining copies of forms submitted to TCEQ:	512/239-0900
Information Services for obtaining reports from program data bases (as available):	512/239-DATA (3282)
Financial Administration's Cashier's office:	512/239-0357 or 512/239-0187

Notice of Termination Process:

A Notice of Termination is **effective on the date postmarked for delivery to TCEQ**.
When your NOT is received by the program, the form will be processed as follows:

- 1. Administrative Review:** The form will be reviewed to confirm the following:
 - the permit number is provided
 - the permit is active and has been approved
 - the entity terminating the permit is the current permittee
 - the site information matches the original permit record
 - the form has the required original signature with title and date
- 2. Notice of Deficiency:** If an item is incomplete or not verifiable as indicated above, a phone call will be made to the applicant to clear the deficiency. A letter will not be sent to the permittee if unable to process the form.
- 3. Confirmation of Termination:** A Notice of Termination Confirmation letter will be mailed to the operator.

General Permit (Your Permit)

Coverage under the general permit begins **48 hours after a completed NOI is postmarked for delivery to the TCEQ**. You should have a copy of your general permit when submitting your application. You may view and print your permit for which you are seeking coverage, on the TCEQ web site www.tceq.state.tx.us

General Permit Forms

The Notice of Intent (NOI), Notice of Termination (NOT), and Notice of Change (NOC) with instructions are available in Adobe Acrobat PDF format on the TCEQ web site www.tceq.state.tx.us.

Change in Operator

An authorization under the general permit is not transferable. If the operator or owner of the regulated entity changes, the present permittee must submit a Notice of Termination and the new operator must submit a Notice of Intent. The NOT and NOI must be submitted not later than 10 days prior to the change in Operator status.

TCEQ Central Registry Core Data Form

The Core Data Form has been incorporated into this form. **Do not send a core data form to TCEQ.**

After final acknowledgment of coverage under the general permit, the program will assign a Customer Number (CN) and Regulated Entity Number (RN). For Construction Permits, a new RN will be assigned for each Notice of Intent filed with TCEQ, since construction project sites can overlap with other Customers. The RN assigned to your construction project will not be assigned to any other TCEQ authorization.

You can find the information on the Central Registry web site at <https://www6.tceq.state.tx.us/epay/>. You can search by the Regulated Entity (RN), Customer Number (CN) or Name (Permittee), or by your permit number under the search field labeled "Additional ID" Capitalize all letters in the permit number.

The Customer (Permittee) is responsible for providing consistent information to the TCEQ, and for updating all CN and RN data for all authorizations as changes occur. For General Permits, a Notice of Change form must be submitted to the program area.

Annual Water Quality Fee: This fee is assessed to operators with an active authorization under the general permit on September 1 of each year. The operator will receive an invoice for payment of the annual fee in November of each year. The payment will be due 30 days from the invoice date. A 5% penalty will be assessed if the payment is received by TCEQ after the due date. Annual fee assessments cannot be waived as long as the authorization under the general permit is active on September 1.

It's important for the operator to submit a **Notice of Termination (NOT)** when coverage under the general permit is no longer required. A NOT is effective on the postmarked date of mailing the form to TCEQ. It is recommended that the NOT be mailed using a method that documents the date mailed and received by TCEQ.

• **Mailed Payments:**

You must return your payment with the billing coupon provided with the billing statement.

• **ePAY Electronic Payment:**

Go to <https://www6.tceq.state.tx.us/epay/>

You must enter your account number provided at the top portion of your billing statement. Payment methods include Mastercard, Visa, and electronic check payment (ACH). A transaction over \$500 can only be made by ACH.

INSTRUCTIONS FOR FILLING OUT THE NOT FORM

A. OPERATOR (current permittee.)

1. TCEQ Issued Customer Number (CN)

2. Legal Name of Operator

The operator must be the same entity as previously submitted on the original Notice of Intent for the permit number provided.

3. Operator Mailing Address

Provide a complete mailing address for receiving mail from the TCEQ. Update the address if different than previously submitted in the Notice of Intent or Notice of Change.

4. Phone Number, Fax Number, and E-mail Address

Provide updated contact information.

B. REGULATED ENTITY (RE) INFORMATION ON PROJECT OR SITE

1. Regulated Entity Reference Number (RN)

2. Site/Project Name/Regulated Entity

Provide the name of the site as previously submitted in the Notice of Intent for the permit number provided.

3. Site/Project (RE) Physical Address

Provide the physical address or location access description as previously submitted for the permit number provided.

C. REASON FOR TERMINATION

Indicate the reason for terminating the permit by checking one of the options. If the reason is not listed then provide an attachment that explains the reason for termination.

Please read your general permit carefully to determine when to terminate your permit. Permits will not be reactivated after submitting a termination form. The termination is effective on the date postmarked for delivery to TCEQ.

D. CERTIFICATIONS

The certification must bear an original signature of a person meeting the signatory requirements specified under 30 Texas Administrative Code (TAC) §305.44.

IF YOU ARE A CORPORATION:

The regulation that controls who may sign an NOI or similar form is 30 Texas Administrative Code §305.44(a)(1) (see below). According to this code provision, any corporate representative may sign an NOI or similar form so long as the authority to sign such a document has been delegated to that person in accordance with corporate procedures. By signing the NOI or similar form, you are certifying that such authority has been delegated to you. The TCEQ may request documentation evidencing such authority.

IF YOU ARE A MUNICIPALITY OR OTHER GOVERNMENT ENTITY:

The regulation that controls who may sign an NOI or similar form is 30 Texas Administrative Code §305.44(a)(3) (see below). According to this code provision, only a ranking elected official or principal executive officer may sign an NOI or similar form. Persons such as the City Mayor or County Commissioner will be considered ranking elected officials. In order to identify the principal executive officer of your government entity, it may be beneficial to consult your city charter, county or city ordinances, or the Texas statute(s) under which your government entity was formed. An NOI or similar document that is signed by a government official who is not a ranking elected official or principal executive officer does not conform to

§305.44(a)(3). The signatory requirement may not be delegated to a government representative other than those identified in the regulation. By signing the NOI or similar form, you are certifying that you are either a ranking elected official or principal executive officer as required by the administrative code. Documentation demonstrating your position as a ranking elected official or principal executive officer may be requested by the TCEQ.

If you have any questions or need additional information concerning the signatory requirements discussed above, please contact the Texas Commission on Environmental Quality's Environmental Law Division at 512/239-0600.

30 Texas Administrative Code

§305.44. Signatories to Applications.

(a) All applications shall be signed as follows.

(1) For a corporation, the application shall be signed by a responsible corporate officer. For purposes of this paragraph, a responsible corporate officer means a president, secretary, treasurer, or vice-president of the corporation in charge of a principal business function, or any other person who performs similar policy or decision-making functions for the corporation; or the manager of one or more manufacturing, production, or operating facilities employing more than 250 persons or having gross annual sales or expenditures exceeding \$25 million (in second-quarter 1980 dollars), if authority to sign documents has been assigned or delegated to the manager in accordance with corporate procedures. Corporate procedures governing authority to sign permit or post-closure order applications may provide for assignment or delegation to applicable corporate positions rather than to specific individuals.

(2) For a partnership or sole proprietorship, the application shall be signed by a general partner or the proprietor, respectively.

(3) For a municipality, state, federal, or other public agency, the application shall be signed by either a principal executive officer or a ranking elected official. For purposes of this paragraph, a principal executive officer of a federal agency includes the chief executive officer of the agency, or a senior executive officer having responsibility for the overall operations of a principal geographic unit of the agency (e.g., regional administrator of the EPA).

MARCH 5, 2008
TPDES GENERAL PERMIT
TXR150000